

DRONACHARYA
GROUP OF INSTITUTIONS

ENGINEERING PHYSICS LAB

SUBJECT CODE: BAS- 151/251

B.TECH.(First Year Applied Science)

SEMESTER - I / II

Student Name:	
Roll. No.:	
Branch/Section:	

Dronacharya Group of Institutions

Plot No. 27, Knowledge Park-3, Greater Noida, Uttar Pradesh 201308

Affiliated to

Dr. A P J Abdul Kalam Technical University

Lucknow, Uttar Pradesh 226031

Table of Contents

1. Vision and Mission of the Institute.
2. Vision and Mission of the Department.
3. Program Educational Objectives (PEOs).
4. Program Outcomes (POs).
5. University Syllabus.
6. Course Outcomes (COs).
7. Course Overview.
8. List of Experiments mapped with COs.
9. DO's and DON'Ts.
10. General Safety Precautions.
11. Guidelines for students for report preparation.
12. Lab Experiments.

Vision of the Institute

“Instilling core human values and facilitating competence to address global challenges by providing Quality Technical Education.”

Mission of the Institute

M1 - Enhancing technical expertise through innovative research and education, fostering creativity and excellence in problem-solving.

M2 - Cultivating a culture of ethical innovation and user-focused design, ensuring technological progress enhances the well-being of society.

M3 - Equipping individuals with the technical skills and ethical values to lead and innovate responsibly in an ever-evolving digital landscape.

Vision of Applied Science Department

- To inculcate a strong foundation in budding technocrats in the field of basic sciences and technology empowering them to learn engineering better and contribute to make a better world.

Mission of Applied Science Department

M1: To provide a strong foundation of knowledge and practical skills enabling technocrats to utilize scientific principles to give solutions to complex engineering problems.

M2: To guide students towards self-directed learning, self-discipline, and active engagement through innovative teaching and learning approaches.

M3: To inculcate values and ethics in students and make them responsible citizens of India.

Programme Educational Objectives (PEOs)

PEO1: Students basic concepts in applied science will be enhanced that is necessary for success in industry or in engineering practices as well as advanced study.

PEO2: Students will be equipped with problem-solving, laboratory, and design skills essential for technical careers focused on addressing critical challenges.

PEO3: Students will possess the ability to maintain the environmental serenity while adapting to the dynamic changes in the industry

Program Outcomes (POs)

PO1: Engineering knowledge: Apply the knowledge of mathematics, science, engineering fundamentals, and an engineering specialization to the solution of complex engineering problems.

PO2: Problem analysis: Identify, formulate, review research literature, and analyze complex engineering problems reaching substantiated conclusions using first principles of mathematics, natural sciences, and engineering sciences.

PO3: Design/development of solutions: Design solutions for complex engineering problems and design system components or processes that meet the specified needs with appropriate consideration for the public health and safety, and the cultural, societal, and environmental considerations.

PO4: Conduct investigations of complex problems: Use research-based knowledge and research methods including design of experiments, analysis and interpretation of data, and synthesis of the information to provide valid conclusions.

PO5: Modern tool usage: Create, select, and apply appropriate techniques, resources, and modern engineering and IT tools including prediction and modeling to complex engineering activities with an understanding of the limitations.

PO6: The engineer and society: Apply reasoning informed by the contextual knowledge to assess societal, health, safety, legal and cultural issues and the consequent responsibilities relevant to the professional engineering practice.

PO7: Environment and sustainability: Understand the impact of the professional engineering solutions in societal and environmental contexts, and demonstrate the knowledge of, and need for sustainable development.

PO8: Ethics: Apply ethical principles and commit to professional ethics and responsibilities and norms of engineering practice.

PO 9: Individual and teamwork: Function effectively as an individual, and as a member or leader in diverse teams, and in multidisciplinary settings.

PO10: Communication: Communicate effectively on complex engineering activities with the engineering community and with society at large, such as, being able to comprehend and write effective reports and design documentation, make effective presentations, and give and receive clear instructions.

PO11: Project management and finance: Demonstrate knowledge and understanding of the engineering and management principles and apply these to one's own work, as a member and leader in a team, to manage projects and in multidisciplinary environments.

PO12: Life-long learning: Recognize the need for, and have the preparation and ability to engage in independent and life-long learning in the broadest context of technological change.

University Syllabus

Any ten experiments (at least four from each group).

Group A	
S.No	Name of Practical
1.	To determine the wavelength of sodium light by Newton's ring experiment.
2.	To determine the wavelength of different spectral lines of mercury light using plane transmission grating.
3.	To determine the specific rotation of cane sugar solution using polarimeter.
4.	To determine the focal length of the combination of two lenses separated by a distance and verify the formula for the focal length of combination of lenses.
5.	To measure attenuation in an optical fiber.
6.	To determine the wavelength of He-Ne laser light using single slit diffraction
7.	To study the polarization of light using He-Ne laser light.
8.	To determine the wavelength of sodium light with the help of Fresnel's bi-prism.
9.	To determine the coefficient of viscosity of a given liquid.
10.	To determine the value of acceleration due to gravity (g) using compound pendulum
Group B	
1.	To determine the energy band gap of a given semiconductor material.
2.	To study Hall Effect and determine Hall coefficient, carrier density and mobility of a given semiconductor material using Hall effect setup.
3.	To determine the variation of magnetic field with the distance along the axis of a current carrying coil and estimate the radius of the coil.
4.	To verify Stefan's law by electric method
5.	To determine resistance per unit length and specific resistance of a given resistance using Carey Foster's Bridge.
6.	To study the resonance condition of a series LCR circuit.
7.	To determine the electrochemical equivalent (ECE) of copper.
8.	To calibrate the given ammeter and voltmeter by potentiometer.
9.	To draw hysteresis (B-H curve) of a specimen in the form of a transformer and to determine its hysteresis loss.
10.	To measure high resistance by leakage method.

Course Outcomes

At the end of the course, students will be able to

CO	CO Statement	Bloom's Level
CO 1	Apply the principle of interference and diffraction to find the wavelength of monochromatic and polychromatic light.	Apply
CO 2	Compute and analyze various electrical and electronic properties of a given material by using various experiments.	Analyze
CO 3	Verify different established laws with the help of optical and electrical experiments.	Apply
CO 4	Determine and calculate various physical properties of a given material by using various experiments.	Apply
CO 5	Study and estimate the performance and parameter of given equipment by using graphical and computational analysis.	Apply

Course Overview

The main objective of this course is to gain practical knowledge by applying experimental methods to correlate with the theory.

1. Apply analytical techniques and graphical analysis to the experimental data.
2. To develop intellectual communication skills and discuss the basic understanding of various experimental principles involved.
3. Analyze the behavior and characteristics of various materials for its optimum utilization.

List of Experiments mapped with COs

S. No	Aim of the	COs
1.	To determine the wavelength of sodium light by Newton's ring experiment.	CO1
2.	To determine the wavelength of different spectral lines of mercury light using plane transmission grating.	CO1
3.	To determine the coefficient of viscosity of a given liquid.	CO4
4.	To determine the specific rotation of cane sugar solution using polarimeter.	CO4
5.	To determine the variation of magnetic field with the distance along the axis of a current carrying coil and estimate the radius of the coil.	CO5
6.	To determine resistance per unit length and specific resistance of a given resistance using Carey Foster's Bridge.	CO2
7.	To determine the energy band gap of a given semiconductor material	CO2
8.	To verify Stefan's law by electric method.	CO3/ CO5
9.	To determine the electrochemical equivalent (ECE) of copper.	CO2
10.	To determine the wavelength of sodium light with the help of Fresnel's bi-prism	CO1

DOs and DON'Ts

DOs

- 1. Always conduct in a responsible manner in the laboratory.**
- 2. Keep the work area clean, neat and free of any unnecessary objects.**
- 3. Carefully read the description, procedure and precautions of the experiment in the lab manual.**
- 4. Place all sensitive electronic equipment safely on an experimental table.**
- 5. Before using the equipment, one must read the labels and instructions carefully.**
- 6. Circuit connections are to be made only in power off mode.**
- 7. Switch of the power in the circuit after completion of the experiment.**
- 8. Be careful when handling optical items like lens, gratings etc.**

DON'Ts

- 1. Do not use mobile phones during experiments specifically based on magnetic fields.**
- 2. Tea, Coffee, Water & Eatables are not allowed in the Physics Lab.**
- 3. Never rewire or adjust any element of a closed circuit.**
- 4. Avoid dangling electrical cords as they can cause electrical shocks and injuries.**
- 5. Make sure all heating devices and gas valves are turned off before leaving the laboratory.**
- 6. Exercise caution when handling liquids in the vicinity of electrical equipment.**
- 7. Use gloves to pick up broken pieces of glass or ceramics.**

General Safety Precautions

Precautions (In case of Injury or Electric Shock)

1. To break the victim with live electric source, use an insulator such as firewood or plastic to break the contact. Do not touch the victim with bare hands to avoid the risk of electrifying yourself.
2. Unplug the risk of faulty equipment. If the main circuit breaker is accessible, turn the circuit off.
3. If the victim is unconscious, start resuscitation immediately, use your hands to press the chest in and out to continue breathing function. Use mouth-to-mouth resuscitation if necessary.

Precautions (In case of Fire)

1. Turn the equipment off. If the power switch is not immediately accessible, take the plug off.
2. If the fire continues, try to curb the fire, if possible, by using the fire extinguisher or by covering it with a heavy cloth, if possible, isolate the burning equipment from the other surrounding equipment.
3. Sound the fire alarm by activating the nearest alarm switch located in the hallway.

Guidelines to Students for Report Preparation

All students are required to maintain a record of the experiments conducted by them. Guidelines for its preparation are as follows: -

- 1) All files must contain a title page followed by an index page. *The files will not be signed by the faculty without an entry in the index page.*
- 2) Student's Name, roll number and date of conduction of experiment must be written on all pages.
- 3) For each experiment, the record must contain the following
 - (i) Aim/Objective of the experiment
 - (ii) Procedure/method
 - (iii) Theory and Formulae
 - (iv) Observations and Calculations (on Blank page)
 - (v) Diagram (on blank page)
 - (v) Results and percentage error (if any)

Note:

1. Students must bring their lab record along with them whenever they come to the lab.
2. Students must ensure that their lab record is regularly evaluated.

LAB EXPERIMENTS

Experiment 1:

Aim: To determine the wavelength of sodium light by Newton's ring experiment.

Apparatus: A nearly monochromatic source of light (source of sodium light), a plano-convex lens C, an optically plane glass plate P, an optically flat glass plate G inclined at an angle of 45° , a travelling microscope with measuring scale and a spherometer.

Formula used:

The wavelength λ of light is given by the formula:

$$\lambda = \frac{(D_{m+n})^2 - (D_n)^2}{4mR}$$

Where, D_{m+n} = diameter of $(m+n)^{\text{th}}$ ring,

D_n = diameter of n^{th} ring,

m = an integer number (of the rings)

R = radius of curvature of the curved face of the plano-convex lens.

Description of apparatus:

The optical arrangement for Newton's ring is shown in fig. (1). Light from a monochromatic source (sodium lamp) is allowed to fall on the convex lens through a broad slit which renders it into a nearly parallel beam. Now it falls on a glass plate inclined at an angle 45° to the vertical, thus the parallel beam is reflected from the lower surface. Due to the air film formed by a glass plate and a plano-convex lens of large radius of curvature, interference fringes are formed which are observed directly through a travelling microscope. The rings are concentric circles.

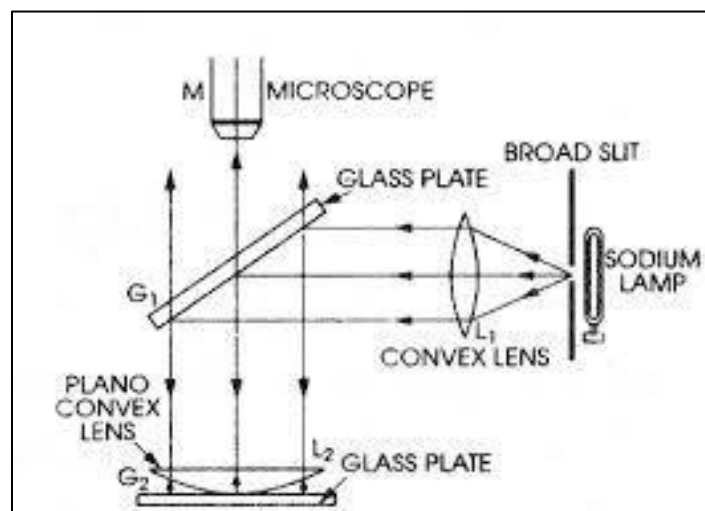

Figure 1

Theory:

A plano-convex lens is placed with its convex surface on the optically plane glass plate so as to enclose a thin film of air of varying thickness between the lens and the plate. Light from an extended monochromatic source (i.e. sodium lamp) of light is converted into a parallel beam of light by using a convex lens 'L1' of short focal length and made to fall on an optically plane glass plate inclined at an angle of 45° to the vertical, where it gets reflected on to the plano-convex lens 'L2' as shown in Fig.1 Interference takes place between the rays of light reflected from the upper and the lower surfaces of the wedge shaped air film enclosed between lens L2 and glass plate P and circular interference fringes (alternate dark & bright) called Newton's rings are produced as shown in Fig.2

The center will be dark because at the center, lens is in contact with the glass plate and thickness of air film at the center is zero. By Stoke's law, a phase change of (or path difference of Fig.2) takes place due to the reflection at the lower surface of the film (Fig.3) as the ray of light passes from rarer to denser medium. As we proceed outwards from the center, the thickness of the film gradually increases, being the same all along the circle with the center at the point of contact. Thus, the fringes produced are concentric circles and localized in the air film. The fringes can be viewed by means of a low power travelling microscope 'M' as shown in Fig.1

The fringes are circular since air film is symmetrical about the point of contact. The locus of all the points at same thickness is a circle i.e., all the points where the air film has a given thickness lie on a circle whose center is at 'O'

Let 'R' be the radius of curvature of the surface of plano-convex lens in contact with the glass plate P.

D_n = diameter of the n dark ring

λ = Wavelength of monochromatic source of light used

then, **$D_n^2 = 4nR\lambda$**

It may be pointed out that surfaces of the lens and the plate may not be clean and the lens may not be perfect contact with the glass plate at the center. The center will not be dark. To eliminate the error due to this problem, the diameter of any two dark rings say, n^{th} and $(m+n)^{\text{th}}$ may be determined.

Therefore,

$D_n^2 = 4nR\lambda$ (1)

$D_{m+n}^2 = 4(m+n)R\lambda$ (2)

From equations (1) and (2), we get

$$\lambda = (D_{m+n}^2 - D_n^2) / 4(m)R \dots \dots \dots (3)$$

Since this formula involves the difference of the squares of the diameters of two rings and is independent of the thickness of the air film at the point of contact 'O', the above error is minimized. Therefore, diameter of the ring depends upon the wavelength of light used.

In the figure:

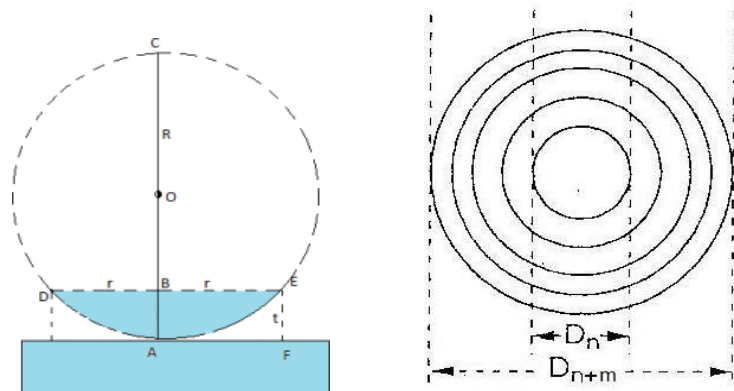

Figure 2

Here R is the radius of curvature of the lens that can be found with a spherometer using the relation.

$$R = \frac{l^2}{6h} + \frac{h}{2}$$

where l is the distance between the two legs of the spherometer and h is the height or the thickness of the lens at the center.

Procedure:

1. Find the least count of micrometer scale.
2. Clean the surface of glass plate 'G', glass plate 'P' and the Plano-convex lens L, Put them in position as shown in Fig.1 in front of the sodium lamp.
3. Switch on the sodium lamp and see that only parallel beam of light coming from the convex lens on the glass plate 'G'
4. Adjust the position of microscope so that it lies vertically above the center of lens L. Focus the microscope so that alternate dark and bright rings are clearly visible.
5. Adjust the position of the microscope till the point of intersection of the crosswires coincides with the center of the ring system and one of the vertical cross-wires is perpendicular to the horizontal scale.
6. Move the microscope to the left with the help of micrometer screw so that the vertical

cross wire lies tangentially at one of the extreme ends of the 20th dark ring.

7. Note the reading of the micrometer scale 'a' of the microscope.
8. Slide the microscope backward with the help of micrometer screw and go on noting the readings when the cross wire lies tangentially at the extreme ends of horizontal diameter of 16th, 12th, 8th and 4th dark rings in column 'Left (a)' respectively.
9. Continue sliding the microscope to the right and note down the readings in column 'Right (b)' when the vertical cross wires lies tangentially at the other extreme end of the diameter of 4th, 8th, 16th and 20th dark rings respectively.
10. Now slide the microscope backwards and again note down the readings corresponding to the same rings on the right and then on the left to the center of the ring system in column 'Right(c)' and 'Left (d)'.

Observations:

Value of one division of the main scale

No. of divisions on the vernier scale =

Least count of the microscope =

S.No.	No. of the ring	LHS reading in cm			RHS reading in cm			Diameter $D_n=(L-R)$	$(D_n)^2$ cm ²	$(D_{m+n})^2 - (D_n)^2$
		MSR	VSR	TR(L)	MSR	VSR	TR(R)			
1								$a =$	$d-a =$	
2								$b =$		
3								$c =$	$e-b =$	
4								$d =$		
5								$e =$	$f-c =$	
6								$f =$		

Calculations:

The wavelength of sodium light is given by:

$$\lambda = \frac{(D_{m+n})^2 - (D_n)^2}{4mR}$$

Result:

The mean wavelength λ of sodium light =..... A

Standard mean wavelength $\lambda = 5890$ A

Percentage error = %

Sources of Error and Precautions:

- i) Glass plates and lens should be cleaned thoroughly.
- ii) The lens used should be of large radius of curvature.
- iii) The source of light used should be an extended one.
- iv) Before measuring the diameter of rings, the range of the microscope should be properly adjusted.
- v) Crosswire should be focused on a bright ring tangentially.
- vi) Radius of curvature should be measured accurately.

VIVA-VOCE QUESTIONS

- 1. What happens if the light rays are incident obliquely instead of normal incidence?
- 2. What will happen if a plane mirror is placed in place of a glass plate in Newton's rings experiment?
- 3. If white light is used in place of monochromatic light, how are Newton's rings affected?
- 4. Why the fringes obtained are circular and concentric?
- 5. Why is the center of circular fringes dark?
- 6. How are the fringes formed?
- 7. What will happen if a transparent liquid in Newton's rings experiment replaces air in the interspace?
- 8. Newton's rings are broader near the center and sharper towards the edge. Why?
- 9. What is the cause of the formation of Newton's rings?

Experiment 2

Aim: To determine the wavelength of spectral lines of mercury light by a plane transmission grating

Apparatus: Mercury lamp, Spectrometer, a spirit level, grating with stand, table lamp and a reading lens.

Formula used: The wavelength of any spectral line can be obtained from the formula.

$$(a+b) \sin\theta = n \lambda$$

$$\lambda = \frac{(a+b) \sin \theta}{n}$$

Where,

$(a+b)$ = grating element

θ = angle of diffraction

n = order of spectrum

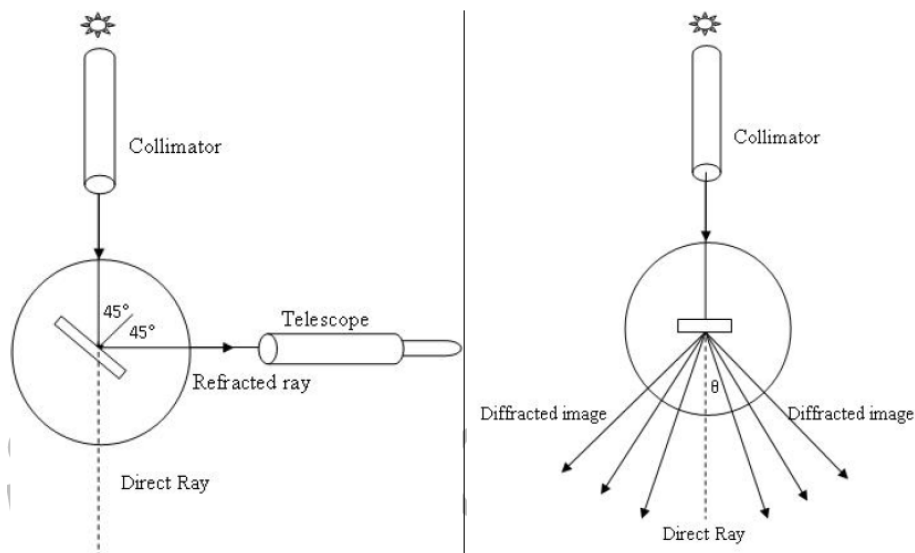

Figure 1 Setting diffraction grating normal to the incident light.

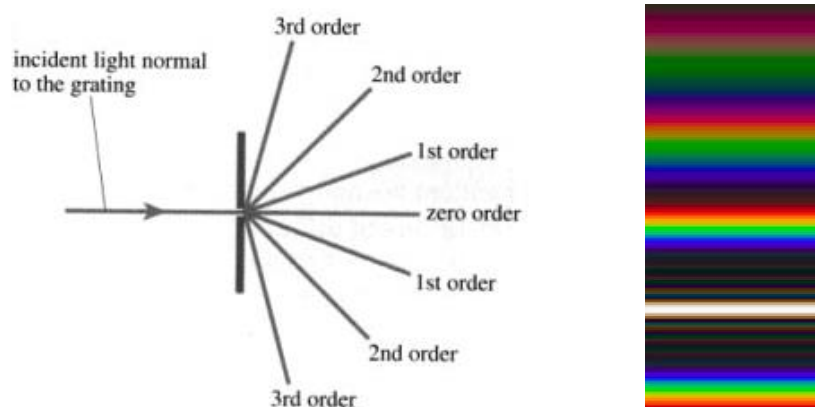

Figure 2 Orders and spectrum obtain visible through the diffraction grating.

Procedure:

1. Set the spectrometer by adjusting the position of the eyepiece of the telescope so that the crosswire is clearly visible. Focus the telescope on a distance object for parallel rays. Level the spectrometer and prism table with spirit level.
2. Set the grating on prism table with help of two screws P and Q provided on the table. Take out the grating from the box carefully, holding it from the edge and without couching its surface towards the telescope.
3. The telescope is rotated by 90^0 towards the left side of direct image and the diffraction grating is placed on the grating table.
4. The grating should be adjusted by rotating the grating table without touching the telescope such that the slit gets appeared at the crosswire of the eyepiece.
5. When the slit is seen clearly, we rotate the grating table 45° towards the right. So, the diffraction gratings become normal to the incident light and ruled surface focus the telescope.
6. Now, the telescope should be again brought in its original position by rotating it 90^0 towards right.
7. Focus the telescope for different colors violet, green, red, etc. (VIBGYOR) by moving telescope slowly on either side from normal position. It was the first order spectrum.
8. Now, the second order spectrum may be viewed by further rotating the telescope in the same direction.
9. After taking the measurement for first order spectrum on both sides, i.e., by noting V1 and V2 (main scale and vernier scale), we turn the telescope for the other side (say, right or left). It is now focused on the same colors or spectral lines and the reading of the crosswire on the scale is recorded.
10. Finally, the same procedure is repeated for other colors (spectral lines) as well as for other orders of the spectrum.

Observations:

Table for determination of angle of diffraction:

Least count of spectrometer =

Number of lines per inch on the grating N =

Grating element $(a+b) = 2.54/N$ cm

Order of spectrum	Color of light	Kind of vernier	Spectrum on left side reading of telescope. (a)			Spectrum on right side reading of telescope. (b)			2θ=(a-b)	Mean θ in degree
			MS	VS	Total	MS	VS	Total		
First	Violet	V1								
		V2								
	Green	V1								
		V2								
	Red	V1								
		V2								
Second	Violet	V1								
		V2								
	Green	V1								
		V2								
	Red	V1								
		V2								

Calculations: Grating element,

$$(a + b) = \frac{2.54}{N} = \dots\dots\dots\text{cm}^{-1}.$$

Where, *N* is number of ruling per inch on the grating.

I. The wavelength of various spectral lines in the first order (*n* = 1) can be calculated by

$$\lambda = \frac{(a + b) \sin \theta}{1} = (a + b) \sin \theta$$

$\lambda_{violet}^I = \dots\dots\dots \text{Å}$, $\lambda_{yellow}^I = \dots\dots\dots \text{Å}$ and $\lambda_{red}^I = \dots\dots\dots \text{Å}$

II. Wavelength in second order (*n* = 2) is given by

$$\lambda = \frac{(a + b) \sin \theta}{2}$$

$\lambda_{violet}^{II} = \dots\dots\dots \text{Å}$, $\lambda_{yellow}^{II} = \dots\dots\dots \text{Å}$ and $\lambda_{red}^{II} = \dots\dots\dots \text{Å}$

Result: The wavelength is given in the table.

Colour of spectral line	Calculated wavelength	Standard wavelength	% Error
Violet		4358 Å	
Yellow		5770 Å, 5791 Å	
Red		6678 Å, 7065 Å	

Precautions and sources of error:

1. Before performing the experiment, the spectrometer should be adjusted.
2. Slit should be as narrow as possible.
3. Grating should be set normal to the incident light.
4. While taking observation, telescope and prism table should be kept fixed.
5. Both vernier should be read.

Experiment 3

Aim: To determine the value of unknown resistance of given wire using Carey foster's bridge.

Apparatus: Carey foster's bridge, two equal resistances, copper strip, a fractional resistance box, a cell, connecting wire, a sensitive galvanometer, a jockey and one way key.

Theory and formula used:

The unknown resistance Y of the experimental wires whose specific resistance K is to be determined, is obtained by the formula.

$$Y = X - \rho(l_2 - l_1)\text{ohms}$$

Where X is the resistance introduced in the decimal ohm box (R.B), Y is the resistance of the experimental wire connected in one of the outer gaps of the Carey foster's bridge, l_1 the length of the balance point on the bridge wire when the resistance box R.B. is in the left outer gap or unknown resistance is in right outer gap, l_2 the length of the balance point on the bridge wire when the resistance box R.B.(or resistance X) is in the right outer gap of the bridge or unknown resistance is in left outer gap and P the resistance per unit length of the bridge wire (between A and B). The specific resistance of wire using the formula

$$K = \frac{Y\pi r^2}{l} \text{ ohm - cm}$$

Where r is the radius and l is the length of experimental wire.

Procedure

1. Arrange the apparatus as shown in fig.
2. Connect the resistance box in the left gap and a copper strip in the right gape of the Carey – Foster's bridge.
3. The sliding contact of the rheostat is set in the middle of it so that the two resistances P and Q are nearly equal.

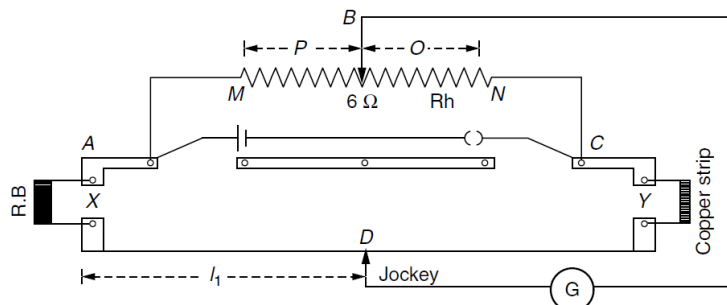

4. Introduce a resistance R in the resistance box and slide the jockey on the wire of Carey – Foster’s Bridge until the null point is obtained. This gives the reading as l_1 .
5. Interchange the position of resistance box and copper strip and obtain null point again by sliding the jockey on the wire. This gives the reading as l_2 .
6. Change the value of resistance R and obtain different sets of observations.
7. Calculate the value of resistance per unit length ρ for each set of observation using the formula $\rho = \frac{R}{(l_2 - l_1)}$ and calculate the value of ρ .
8. Connect the resistance box in the left gap and a given wire in the right gap of the Carey Foster’s bridge and find l_1 and l_2 . Only change is that copper strip is replaced by a given wire.
9. Calculate the resistance of the wire using

$$Y = R - \rho(l_1 \sim l_2).$$

Take different sets by changing the value R in the decimal resistance box.
10. Calculate the radius of a given wire using screw gauge and measure the effective length of the wire.

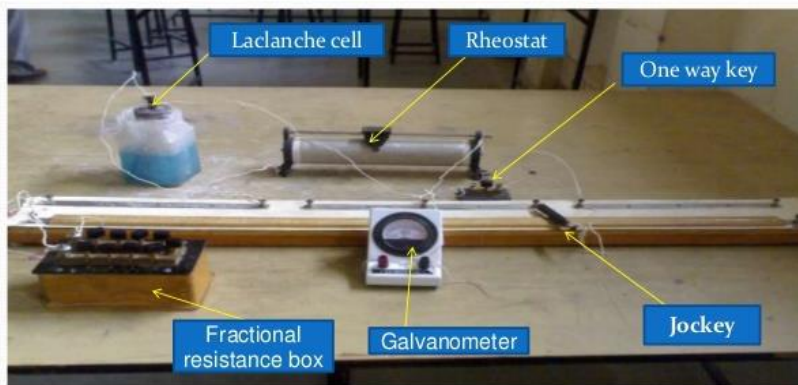

Observation Table:

Table 1. Measurement of ‘ ρ ’

S. No.	Resistance introduced ‘R’ (ohm)	Position of the balance point (cm.)		$(l_2 \sim l_1)$ cm.	$\rho = \frac{R}{(l_2 \sim l_1)}$ (ohm / cm.)	Mean ρ (ohm / cm.)
		l_1 cm.	l_2 cm.			
1.						
2.						
3.						
4.						
5.						

Table 2. : Measurement of Wire resistance:-

S. No.	Resistance introduced R (ohm)	Position of the Balance Point		(l ₂ - l ₁) cm.	Y = R - ρ(l ₁ ~ l ₂) (ohm)	Mean R''(ohm)
		l ₁ cm.	l ₂ cm.			
1.						
2.						
3.						
4.						
5.						

Calculations:

(A) The resistance per unit length of the bridge wire is calculated with the help of the formula.

$$\rho = \frac{R}{(l_2 \sim l_1)} \text{ Ohm}$$

Calculate ρ for the different sets and taken mean.

(B) The resistance if the wire is calculated by $Y = R - \rho(l_1 \sim l_2)$ Ohm.

(C) Calculate the specific resistance of wire using the formula

$$K = \frac{Y \pi r^2}{l} \text{ ohm - cm}$$

Result:

- a. The length of the given wire = cm.
- b. The Specific resistance of the given wire = ohm – cm.

Precaution:

1. In ordered that the bridge may have high sensitiveness, the resistance of the four arms should be of same order.
2. A plug key should be included in the cell circuit and should be closed when observations are being made.
3. The jockey should be pressed gently and momentarily. It should not be pressed on the wire.

Experiment 4

Aim: To Study the temperature dependence of resistivity of a semiconductor (Four probe method) and to determine band gap of experimental material (Ge).

Apparatus Required:

Four probe apparatus, sample (a Ge crystal in form of a chip), oven, thermometer, constant power supply, oven power supply, panel meters for measurement of current and voltage.

Formula Used : Resistivity of a semiconductor is

$$\rho = A \exp\left(\frac{E_g}{2k_B T}\right)$$

Where E_g is Band Gap in eV

k_B is Boltzman constant = 8.617×10^{-5} eVK⁻¹

and T is absolute Temperature

Principle :

Ohm's law: If physical conditions (like temperature, mechanical stress) remains unchanged, then potential difference across two ends of a conductor is proportional to current flowing through it

$$V \propto I$$

$$V = IR$$

The constant of proportionality, R, is called resistance of the conductor.

Resistivity: At a constant temperature, the resistance, R, of a conductor is (i) proportional to its length and (ii) inversely proportional to its area of cross-section,

$$R = \rho \frac{L}{A}$$

The constant of proportionality, ρ , is called resistivity of material of the conductor. Resistivity of a material is equal to the resistance offered by a wire of this material of unit length and unit cross-sectional area. Unit of resistance is ohm (Ω), and unit of resistivity is ohm-meter ($\Omega\text{-m}$)

Four probe method: The 4-point probe set up (Fig.I & Fig.II) consists of four equally spaced tungsten metal tips with finite radius. Each tip is supported by springs on the end to minimize sample damage during probing. The four metal tips are part of an auto-mechanical stage which travels up and down during measurements. A high impedance current source is used to supply current through the outer two probes, a voltmeter measures the voltage across the inner two probes to determine the sample resistivity. Typical probe spacing ~ 2 mm. These inner probes draw no current because of the high input impedance voltmeter in the circuit. Thus unwanted voltage drop ($I R$ drop) at point B and point C caused by contact resistance between probes and the sample is eliminated from the potential measurements. Since these

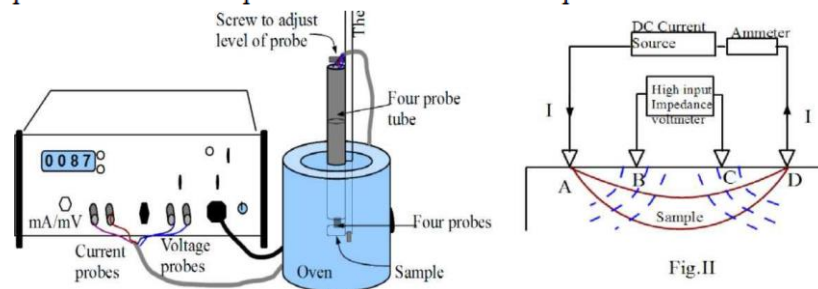

Fig. 1: Schematic diagram of a Four Probe

In order to use this four-probe method in germanium crystals or slices it is necessary to assume that:

The resistivity of the material is uniform in the area of measurement and a non-conducting boundary is produced when the surface of the crystal is in contact with an insulator. The derivation of equations given below is involved. For each case it is assumed that the probes are equally spaced (spacing =s).

Case I: Resistivity Measurements on a Large Sample:

We assume that the metal tip is infinitesimal and sample are semi infinite in lateral dimensions. For bulk samples where the sample thickness, $W \gg S$, the probe spacing, we assume a spherical protrusion of current emanating from the outer probe tips. The resistivity is computed to be

$$\rho_o = \left(\frac{V}{I}\right) * 2\pi s$$

where

V = floating potential difference between the inner probes, unit: volt

I =current through the outer pair of probes, unit: ampere

s = spacing between point probes, unit: meter

ρ_o = resistivity, unit: ohm meter

Case II: Resistivity Measurements on a Thin Slice-Nonconducting Bottom Surface:

For the case of a nonconducting bottom on a slice the resistivity is computed from

$$\rho = \frac{\rho_o}{G_7\left(\frac{W}{S}\right)}$$

$G_7\left(\frac{W}{S}\right)$ can be calculated from graph (1) or from Table (1) given below or using formula

$$G_7(w/s) = \frac{2s}{w} \log_e 2$$

Table 1

S.No.	W/S	$G_7(W/S)$	S.No.	W/S	$G_7(W/S)$
1.	0.100	13.863	6.	1.000	1.504
2.	0.141	9.704	7.	1.414	1.223
3.	0.200	9.631	8.	2.000	1.094
4.	0.330	4.159	9.	3.333	1.0228
5.	0.500	2.780	10.	5.000	1.0070

Temperature dependence of resistivity of a semiconductor:

Intrinsic semi-conduction: The process in which thermally or optically excited electrons contribute to the conduction is called intrinsic semi-conduction. In the absence of photonic excitation, intrinsic semi conduction takes place at temperatures above 0 K as sufficient thermal agitation is required to transfer electrons from the valence band to the conduction band. Conductivity for intrinsic semi-conduction. The total electrical conductivity is the sum of the conductivities of the valence and conduction band carriers, which are holes and electrons, respectively. It can be expressed as:

$$\sigma = e(n_e\mu_e + n_h\mu_h)$$

where n_e, μ_e are the electron's concentration and mobility,
and n_h, μ_h are the hole's concentration and mobility, respectively.

Drift mobility determines the average drift velocity in the presence of an applied external field. It also depends on the temperature. The mobility is a quantity that directly relates the drift velocity v_d of charge carriers to the applied electric field E across the material, i.e.,

$$\mu = v_d / E \dots\dots\dots (2)$$

In the intrinsic region the number of electrons is equal to the number of holes, $n_e = n_h = n_i$, so Equation (1) implies that,

$$\sigma = en_i (\mu_e + \mu_h) \dots\dots\dots (3)$$

The electron density (electrons/volume) in the conduction band is obtained by integrating (density of states x probability of occupancy of states) from the bottom to top of the conduction band. The detailed calculations reveal that

$$n_i = NT^{\frac{3}{2}} \exp\left(-\frac{E_g}{2k_B T}\right) \dots\dots\dots (4)$$

Where N is a constant substituting n_i in eq (3)

$$\sigma = e (\mu_e + \mu_h) NT^{\frac{3}{2}} \exp\left(-\frac{E_g}{2k_B T}\right) \dots\dots\dots (5)$$

This shows that conductivity depends on temperature it decreases exponentially with decrease in temperature.

Temperature dependence of resistivity

$$\rho = \frac{\exp\left(\frac{E_g}{2k_B T}\right)}{e (\mu_e + \mu_h) NT^{\frac{3}{2}}} \dots\dots\dots (6)$$

Or,

Where A is a constant Taking Log

$$\ln \rho = \ln A + \frac{E_g}{2k_B T} \dots\dots\dots (8)$$

or

$$\log \rho = C + \frac{1}{2.3026} * \frac{E_g}{2k_B T} \dots\dots\dots (9)$$

where C is a constant . Rewriting eq (9)

$$\log \rho = C + \frac{1}{2.3026 * 10^3} * \left(\frac{E_g}{2k_B}\right) \left(\frac{1000}{T}\right).$$

Therefore, if a graph is plotted $\log \rho$ vs $\left(\frac{1000}{T}\right)$ it should be a straight line and band gap E_g can be determined from its slope as follows :

1. Slope = $\frac{AC}{BC} = \frac{1}{2.3026 * 10^3} * \frac{E_g}{2k_B}$,
2. Band gap $E_g = 2.3026 * 10^3 * 2 * k_B * \text{slope eV}$, (Take Boltzman constant $k_B = 8.617 * 10^{-5} \text{ eVK}^{-1}$).

Method:

- (1) The setting of 4-point probes on the semiconductor chip is a delicate process. So first understand well the working of the apparatus. The semiconductor chip and probe set are costly.
- (2) Note the values of probe spacing (S) and the thickness (W) of the semiconductor chip. Note the type of semiconductor (germanium or something else).
- (3) Make the circuit as shown in Fig.1. Put the sample in the oven (normally already placed by lab instructor) at room temperature.
- (4) Pass a milliamperage range current (say 5 mA) in the sample using constant current power supply.
- (5) The reading of the current through the sample is measured using milliammeter provided for this purpose. The voltage is measured by a high impedance milli voltmeter connected to the inner probes. The readings can be taken alternately on digital meter provided for this purpose.
- (6) Note temperature of sample (oven) using thermometer inserted in the oven for this purpose.
- (7) The oven temperature is increased a little, and its temperature noted after reaching steady state. Again, the constant current reading (advised to be kept the same) and the corresponding voltage readings are taken.
- (8) Repeat the procedure for different temperatures. Note the data in the observation table.
- (9) For each temperature, calculate the resistivity by using the relation.

$$\rho = \frac{\rho_0}{G_7 \left(\frac{W}{S}\right)} = \left(\frac{V}{I}\right) \left(\frac{2\pi S}{G_7 \left(\frac{W}{S}\right)}\right)$$

- (10) Compute $\log \rho$ and $10^3 / T$ and write it in the observation table.
- (11) Plot a graph between $\log \rho$ and $10^3 / T$. It is a straight line. Find its slope.
- (12) Calculate the band gap using formula

$$E_g = 2.3026 * 10^3 * 2 * k_B * \text{slope eV}$$

Use Boltzman constant $k_B = 8.617 * 10^{-5} \text{ eVK}^{-1}$

($k_B = 1.3806 * 10^{-23} \text{ JK}^{-1}$ and $1\text{eV} = 1.6 * 10^{-19} \text{ J}$)

Observations:

1. Semiconductor chip material = Germanium
2. Spacing (distance) between the probes, $s = 2.0 \text{ mm} = \dots\dots\dots \text{ m}$.
3. Thickness of the sample, $w = 0.5 \text{ mm} = \dots\dots\dots \text{ m}$.

Table : Voltage across the inner probes for a constant current at different sample temperatures

Current (I) =mA

S.No.	Temperature T (K)	Voltage across inner probes (mV)	$\frac{1000}{T} K^{-1}$ (calculated)	Resistivity ρ $\rho = \left(\frac{V}{I}\right) \left(\frac{2\pi s}{G_7\left(\frac{W}{S}\right)}\right)$ (ohm-cm)	Log ρ (calculated)
1					
2					
3					
..					

Calculations:

- For the given sample $\left(\frac{W}{S}\right) = \dots\dots\dots$
- The correction factor $G_7(w/s) =$ (from table 1 or graph 1) or calculate $G_7(W/S)$ as follows:

$$G_7(w/s) = \frac{2 * s}{W} \ln 2$$

- Calculation of $T (K^{-1})$, ρ (ohm-m) and $\log \rho$

$$\rho = \frac{\rho_0}{G_7\left(\frac{W}{S}\right)} = \left(\frac{V}{I}\right) \left(\frac{2\pi s}{G_7\left(\frac{W}{S}\right)}\right)$$

- The graph between $\frac{1000}{T}$ and $\log \rho$ is plotted as shown in graph (2)
- Slope of the straight line is $\frac{AC}{BC}$
- Energy band gap $E_g = 2.3026 * 2 * k_B * \text{slope} * 10^3$ (in eV)

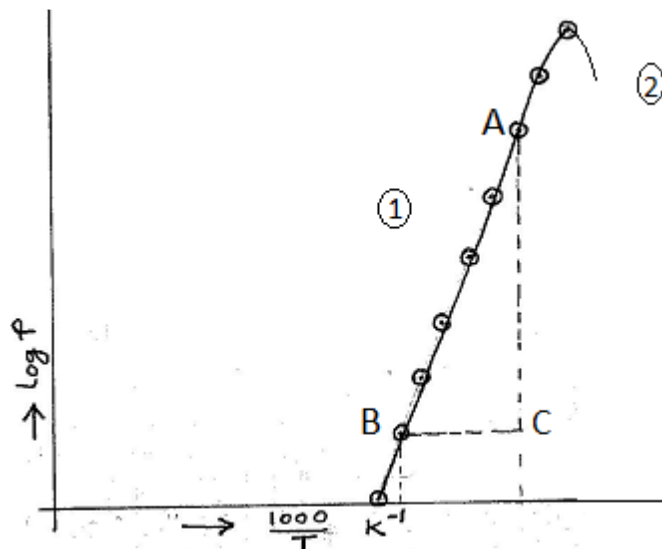

Graph 2 Variation of $\log \rho$ with $\frac{1000}{T}$

Result:

1. The temperature dependence of the resistivity of semiconductor (germanium) chip is as shown in the graph (2). The resistivity decreases exponentially with the increase in T . That is as at low temperatures resistivity is more and at high temperatures the resistivity is less.
2. The energy band gap for the given semiconductor (germanium) is =eV.

Precautions:

1. The surface of the semiconductor should be flat.
2. All the four probes should be collinear.
3. The adjustment of 4-point probes should be done gently, as the semiconductor chip is brittle.
4. The voltage should be measured using inner probes only using a high impedance millivolt meter.
5. Temperature of the oven should not exceed the limits set by manufacturer of the probes and chip

Experiment 5

Aim: To determine the specific rotation of cane sugar solution using half shade polarimeter.

Apparatus: Polarimeter, Polarimeter tube, cane-sugar, Physical Balance, Weight box, measuring cylinder, beaker and source of light.

Formula Used: The specific rotation of the plane of polarization of sugar dissolved in water can be determined by the following formula,

$$S = \frac{\theta}{l.c} = \frac{\theta.V}{m.c}$$

where . θ is rotation produced in degrees

l is length of tube in decimeter

m is mass of sugar in grams dissolved in water

V is volume of sugar solution

Procedure:

1. Take the polarimeter tube and clean well both the sides such that it is free from dust. Now fill the tube with pure water and see that no air bubble is enclosed in it. Place the tube in its position inside the polarimeter. Switch on the source of light and look through the eyepiece.
2. In case of **half shade polarimeter**, two halves of unequal intensity is observed. Left half may be bright and the right half may be dark, or *vice versa*. By rotating the analyzer eyepiece system, the bright-dark pair gets interchanged to dark-bright pair, or *vice versa*. Rotate the analyzer (first in clockwise direction and then in anticlockwise direction) until the intensity of two halves is about to interchanged and circular field of view appears equally bright.
3. In case of **biquartz polarimeter** we find two halves of different colours, one red and other blue. By rotating the analyzer eyepiece system, the colour pair gets interchanged. Let us select a pair of different colour, say red and blue. By rotating the analyzer scale, the colour pair can be interchange to blue and red. At the position of interchange, the two colours can be mixed by rotating the analyzer (first in clockwise direction and then in anticlockwise direction), so that circular field of view appears gray instead of two halves of red and blue.
4. Take the first reading at equal intensity position (either bright or gray) and also record the second reading at 180° apart from this position, in both the directions (clockwise and anticlockwise). Find the mean of two directions reading separately for both the position.

(say 10 gm) into 100 ml of water. Take the polarimeter tube and remove the pure water. Fill it with the prepared sugar solution and again place it in the polarimeter.

6. Rotate the analyzer eyepiece system to obtain the equal intensity position, first in clockwise direction and then in anticlockwise direction. Note down the first position of the analyzer scale in the two directions. Find the mean reading. Repeat similarly, for second position at 180° apart.
7. The difference between water and sugar solution reading gives the specific rotation.
8. The experiment can be repeated with sugar solutions of different concentrations.
9. Measure the length of the tube in centimeters and change it in decimeters.

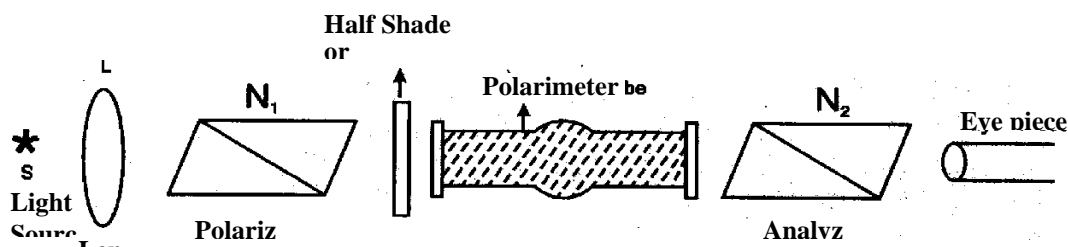

Figure1: Arrangement inside the polarimeter

Observations: Room temperature = °C

(A) Preparation of sugar solution:

Mass of watch glass =gm = kg

Watch glass + sugar =gm = kg

Therefore, mass of sugar taken, m =gm = kg

Volume of the solution V =ml = c.c.

Concentration of the solution $c = m/V = \dots\dots\dots \text{gm} / \text{c.c.} = \dots\dots\dots \text{kg/m}^3$

Length of the polarimeter tube l =cm = decimeter

(B) Tables for the determination of specific rotation:

Value of one division of the main scale =

No. of division on vernier scale =|

Least count of vernier =

Analyser reading with pure water						
Clockwise X			Anticlockwise Y			Mean $a = \frac{X+Y}{2}$
MS	VS	Total	MS	VS	Total	

Concentration of solution in gm/cc	Analyser reading with sugar solution						Mean $b = \frac{X+Y}{2}$	$\theta = (b-a)$
	Clockwise X ₁			Anticlockwise Y ₂				
	MS	VS	Total	MS	VS	Total		

Calculations

$$S = \frac{\theta}{l.c} = \frac{\theta.V}{m.c}$$

Result: The specific rotation of sugar = degree/dm/gm/cc

Sources of error and Precautions:

1. The polarimeter tube should be well cleaned.
2. The water used should be dust free.
3. Whenever a solution is changed, rinse the tube with the new solution under examination.
4. There should be no air bubbles inside the tube.
5. The position of analyzer should be set accurately.
6. The temperature and wavelength of light used should be stated.
7. Reading should be taken when halves of the field of view become equally illuminated.

Experiment 6

Aim: To verify Stefan's law by electric method.

Apparatus Required: Stefan's kit, connecting wires.

Theory & formula used:

According to Stefan's –Boltzmann's law the heat energy E Radiated per unit area per second by a body at temperature T surrounded by another body at temperature T_0 then by Stefan's law

$$E \propto (T^4 - T_0^4)$$

Or
$$E = \sigma \cdot (T^4 - T_0^4) \dots\dots\dots (1)$$

Where, σ = Stefan's constant. ($5.67 \times 10^{-8} \text{ W/m}^2\text{k}^4$)

For the bodies other than black bodies, the similar relation for the power emitted by a body at temperature T surrounded by another body at temperature T_0 is given as

$$P = C(T^\alpha - T_0^\alpha) \dots\dots\dots (2)$$

Where C is some constant which depends on the material and area of the body and α is a power very close to 4. Further

$$P = CT^\alpha \left(1 - \frac{T_0^\alpha}{T^\alpha}\right)$$

If $T \gg T_0$, then the above relation reduces to

$$P = CT^\alpha \dots\dots\dots(3)$$

Taking logarithm on both sides, we get

$$\log_{10}P = \alpha \log_{10}T + \log_{10}C \dots\dots\dots (4)$$

Eq. (4) gives the straight line graph. Therefore a graph between $\log_{10}P$ & $\log_{10}T$ should be straight line whose slope gives α . The value of α is equal to 4, then Stefan's law is verified.

Procedure:

1. Make the connection and switch on the power supply. Now keep the current at zero position by adjusting the current control knob at minimum.
2. Now filament current I is increased and apply some filament voltage by V_f by adjusting current control knob one by one at 0.2V, 0.4V, 0.6V.....etc, and measure the corresponding filament current I_f in the ammeter after steady state is reached.
3. Repeat the experiment for enough set of observations so that the graph can be plotted between $\log P$ & $\log T$.

Circuit Diagram

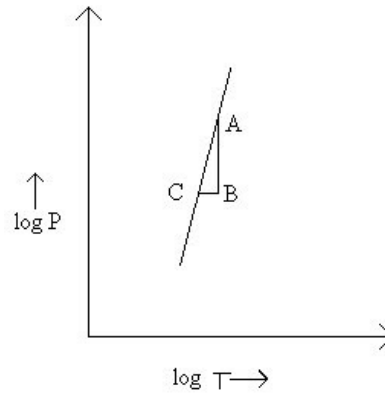
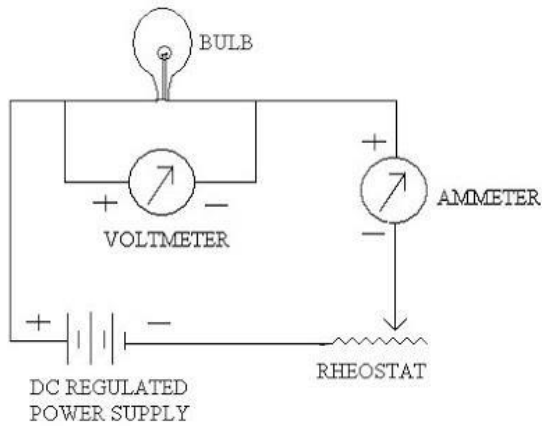

Observation Table:

1. Determination of R_g

S. No	Voltage(V) volt	Current(I) amp	$R_g = \frac{V}{I}$ ohm
1.			
2.			

For $R_0 = R_g / 3.9$

Table2: Determination of Power dissipated for different temperature T.

S. No.	Filament Voltage V_f (Volt)	Filament Current I_f (mA)	Power radiated = $V_f \cdot I_f$ (watt)	Filament resistance = V_f / I_f (ohm) R_T	R_T / R_0	T(K)	logP	logT
1.								
2.								
3.								
4.								
5.								
6.								
7.								

Calculation:

The graph is plotted by taking logT on X-axis & logP on Y-axis. The graph will be a straight line. Find the slop which would be 4. The slop of the curve

$$\frac{\log P}{\log T} = \frac{AB}{BC} = 4$$

Result:

The graph between $\log P$ & $\log T$ is a straight line and slope of straight line is about 4. Hence Stefan's law is verified.

Precautions:

1. The connection should be tight.
2. Take ammeter & voltmeter reading carefully.
3. The slope of straight line should be determined as accurate as possible.

Temp. in °C	R_T/R_0	Temp. in °C	R_T/R_0
0	1.00	1100	7.60
100	1.53	1200	8.26
200	2.07	1300	8.90
300	2.13	1400	9.70
400	3.22	1500	10.43
500	3.80	1600	11.17
600	4.40	1700	11.42
700	5.00	1800	12.67
800	5.64	1900	13.50
900	6.37	2000	14.30
1000	6.94		

Experiment 7

Aim: To determine the variation of magnetic field with the distance along the axis of a current

carrying coil and estimate the radius of the coil.

Apparatus: - Stewart and Gee type galvanometer, Storage battery, rheostat, Millimeter, reversing key, oneway key and connecting wires.

Formula:

If a current carrying coil is placed in y-z plane then its axis will be x-axis. The magnetic field along the axis of coil is given by,

$$B = \frac{\mu_0 NI}{2} \frac{a^2}{(a^2 + x^2)^{3/2}} \quad (1)$$

Where, $\mu_0 (= 4\pi \times 10^{-7})$ is the vacuum permeability, N is the number of turns of the field coil, I is the current in the wire, in amperes, a is the radius of the coil in meters, and x is the axial distance in meters from the center of the coil.

If θ is the deflection produced in magnetometer at a certain position on the axis of coil then magnetic field at that point will be,

$$B = H \tan\theta \quad (2)$$

The equations (1) and (2) implies that the graph between x and $\tan\theta$ will give the variation of magnetic field at the axis of circular coil.

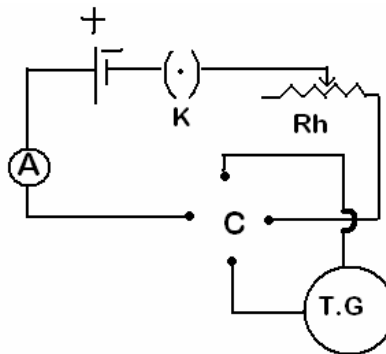

Procedure:

1. Place the instrument in such a way that the arms of the magnetometer lie roughly east and west, and the magnetic needle lies at the centre of the vertical coil. Place the eye a little above the coil and rotate the instrument in the horizontal plane till the coil, the needle and its image in the mirror provided at the base of the compass box, all lie in same vertical plane. The coil is thus set roughly in the magnetic meridian. Rotate the compass box so that the pointer lies on the 0-0 line.
2. Connect all the components as shown in circuit diagram.
3. Adjust the value of the current so that the magnetometer at central position gives a deflection of the order of 700-750. Note this magnetometer reading for both directions of currents. This will give you θ value at $x=0$.
4. Now slide the magnetometer along the +axis of coil with an increment of 2 cm and note the deflection of needle in magnetometer (both ends of needle position) for both directions of current in coil. Record a number of observations. ($x=0,2,4, 6, 8, 10, 12\text{cm}$).

5. After this, repeat the point 4 for the magnetometer position along –axis of coil. i.e., repeat the observation by shifting the magnetometer in the opposite direction and keeping the current constant at the same value.

Observation Table:

Sr. No	Distance of needle from centre, x (cm)	Deflection on East arm				Mean θ in deg.	$\tan \theta$
		Current in one direction		Current in reverse direction			
		θ_1	θ_2	θ_3	θ_4		
1.	2						
2.	4						
3.	6						
4.	8						
5.	10						
6.	12						
7.	14						
8.	16						

Sr. No	Distance of needle from centre, x (cm)	Deflection on East arm				Mean θ in deg.	$\tan \theta$
		Current in one direction		Current in reverse direction			
		θ_1	θ_2	θ_3	θ_4		
1.	2						
2.	4						
3.	6						
4.	8						
5.	10						
6.	12						
7.	14						
8.	16						

Plot in x and $\tan \theta$: The plot of $\tan \theta$ vs x will be found as shown in Fig 3.

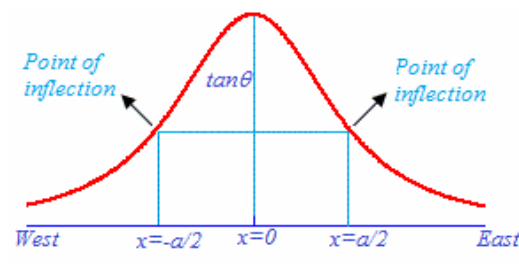

Result:

With help of the graph between $\tan \theta$ and x , following points can be concluded.

1. The intensity of magnetic field is maximum at the centre and goes on decreasing as we move away from the centre of the coil towards right or left.
2. The point on both side of graph where curve becomes convex to concave (i.e. the curve changes its nature) are called the point of inflection. The distance between the two points of

inflexion is equal to the radius of the circular coil.

3. The radius of coil= distance between points of inflection=.....cm

Precautions:

1. There should be no magnet, magnetic substances and current carrying conductor near the apparatus.
2. The plane of the coil should be set in the magnetic medium.
3. The current should remain constant and should be reversed for each observation.

Experiment 8

Aim: To determine the coefficient of viscosity of water, by Poiseuille's method.

Apparatus: A Capillary tube of uniform bore and a constant level reservoir fitted on a board, a

manometer, stopwatch and graduated jar.

Formula used: The coefficient of Viscosity of a liquid is given by the formula.

$$\eta = \frac{\pi Pr^4}{8Vl} = \frac{\pi h \rho g r^4}{8Vl} \text{ Poise or Kg } \underline{\underline{m}}\text{-sec}$$

- Where r = radius of capillary tube
 V = volume of water collected per second
 l = length of the capillary tube
 ρ = density of liquid (ρ = 1.00 × 10³ kg / m³ for water)
 h = difference of levels in manometer

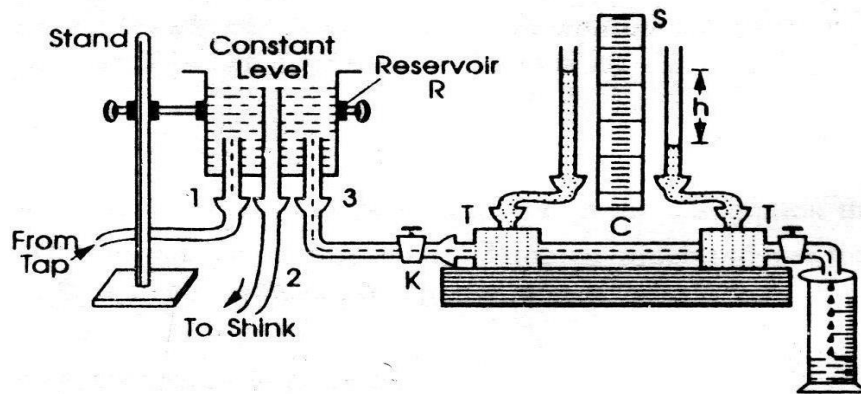

Procedure:

1. Allow the water to enter the constant level reservoir through tube (1) and leave through tube (2) in such a way that water comes drop by drop from the capillary tube. This is adjusted with the help of pinch cock K. It should be remembered that all the bubbles should be removed from the capillary.
2. When everything is steady collect the 10ml water in a graduated jar and note down the time taken and thus calculate the volume V of the water flowing per second.
3. Note the difference of the level of water in manometer. This gives h.
4. Vary h by raising or lowering the reservoir. For each value of h, find the value of V.
5. Measure the length and diameter of the tube.
6. Plot graph h vs v & find its slope.

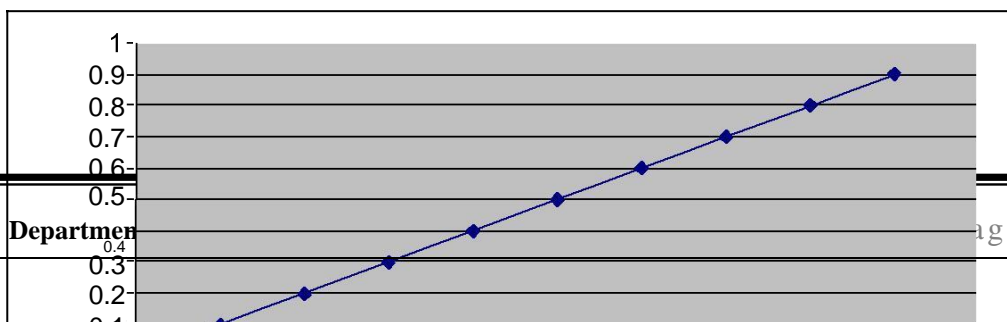

OBSERVATIONS:

Room Temperature=^oC

S. No	Manometer Reading		Pressure Difference h (meter)	Measurement of V		V= meter ³ s
	One end (meter)	Other end (meter)		Total volume of water collected.	Time (t) Sec.	

Mean (h/v)=

Temperature of water =^oC
 Length of capillary tube =cm. =meter.
 Radius of capillary tube(r) =cm. =meter.

Calculations:

The coefficient of viscosity η for water is given:

$$\eta = \frac{\pi r^4 \rho g h}{8 l V}$$

Result: The coefficient of viscosity of water at $^{\circ}\text{C} = \dots\dots\dots$ Poise

This lab manual has been updated by

Dr. Pawan Sharma

(hodaps@gnindia.dronacharya.info)

Cross checked By HOD APS

Verified By

Director, DGI Greater Noida

Please spare some time to provide your valuable feedback.

