

SECTION - A

GENERAL APTITUDE

- Q.1 Writing too many things on the _____ while teaching could make students get _____.
- (a) bored/board (b) board/bored
(c) board/board (d) bored/bored

Ans. (b)

Writing too many things on the board while teaching could make students get bored.

End of Solution

- Q.2 Which one of the following is a representation (not to scale and in bold) of all values of x satisfying the inequality $2 - 5x \leq -\left(\frac{6x-5}{3}\right)$ on the real number line?

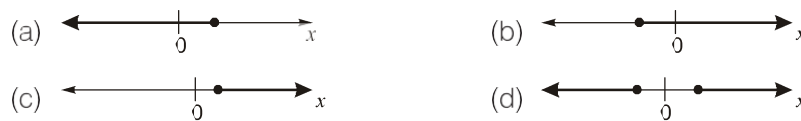

Ans. (c)

$$\begin{aligned} 2 - 5x &\leq -\frac{(6x-5)}{3} \\ \Rightarrow 6 - 15x &\leq -6x + 5 \\ 6 - 5 &\leq -6x + 15x \\ 9x &\geq 1 \\ x &\geq \frac{1}{9} \end{aligned}$$

So, option (c) is correct.

End of Solution

- Q.3 If $f(x) = 2\ln(\sqrt{e^x})$, what is the area bounded by $f(x)$ for the interval $[0, 2]$ on the x -axis?

- (a) $\frac{1}{2}$ (b) 1
(c) 2 (d) 4

Ans. (c)

Given: $f(x) = 2\ln(\sqrt{e^x})$

Area bounded by $f(x)$ within $x \in (0, 2)$ on x -axis is given by,

$$\begin{aligned} A &= \int_0^2 f(x) dx = \int_0^2 2\ln(\sqrt{e^x}) dx \\ &= \int_0^2 2\ln(e^{x/2}) dx = \int_0^2 2 \times \frac{x}{2} \ln e dx = \int_0^2 x dx = \left[\frac{x^2}{2} \right]_0^2 = 2 \end{aligned}$$

End of Solution

- Q.4** A person was born on the fifth Monday of February in a particular year. Which one of the following statements is correct based on the above information?
- The 2nd February of that year is a Tuesday.
 - There will be five Sundays in the month of February in that year
 - The 1st February of that year is Sunday.
 - All Mondays of February in that year have even dates.

Ans. (a)

In a particular year, 5 Mondays can only come in the month of February if that year is a leap year.

So, on 29th February there is a Monday.

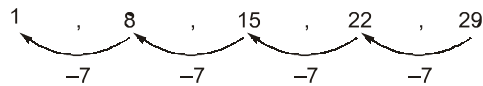

- Option (a) is correct, since 1st February is a Monday and hence 2nd February is a Tuesday.
- Option (b) is incorrect, since only Mondays can be five in February. So, only four Sundays are there.
- Option (c) is incorrect since 1st February is a Monday.
- Option (d) is incorrect as Mondays are on 1th, 8th, 15th, 22nd, 29th February which are all not even dates.

End of Solution

- Q.5** Which one of the groups given below can be assembled to get the shape that is shown above using each piece only once without overlapping with each other? (rotation and translation operations may be used).

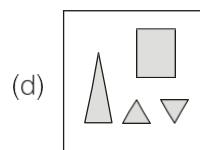
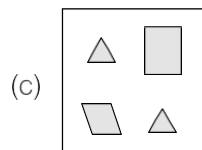
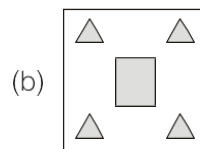
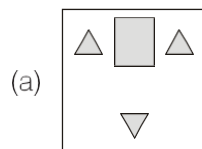
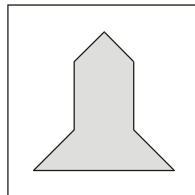

Ans. (b)

End of Solution

Q.6 Fish belonging to species S in the deep sea have skins that are extremely black (ultra-black skin). This helps them not only to avoid predators but also sneakily attack their prey. However, having this extra layer of black pigment results in lower collagen on their skin, making their skin more fragile.

Which one of the following is the CORRECT logical inference based on the information in the above passage?

- (a) Having ultra-black skin is only advantageous to species S .
- (b) Species S with lower collagen in their skin are at an advantage because it helps them avoid predators.
- (c) Having ultra-black skin has both advantages and disadvantages to species S .
- (d) Having ultra-black skin is only disadvantageous to species S but advantageous only to their predators.

Ans. (c)

End of Solution

Q.7 For the past m days, the average daily production at a company was 100 units per day. If today's production of 180 units changes the average to 110 units per day, what is the value of m ?

- (a) 18
- (b) 10
- (c) 7
- (d) 5

Ans. (c)

Total production in m days = $100 \times m$

Total production after today's day i.e. in $(m + 1)$ days
= $100 \times (m + 1)$

The average production after today's production = 110

$$\Rightarrow \frac{100m + 180}{(m + 1)} = 110$$

$$100m + 180 = 110(m + 1)$$

$$100m + 180 = 110m + 110$$

$$70 = 10m$$

$$\Rightarrow m = 7$$

End of Solution

Q.8 Consider the following functions for non-zero positive integers, p and q .

$$f(p, q) = \underbrace{p \times p \times p \times \dots \times p}_{q \text{ terms}} = p^q; \quad f(p, 1) = p$$

$$g(p, q) = p^{\overbrace{p \times p \times p \times \dots \times p}^{\text{(upto to } q \text{ terms)}}}; \quad g(p, 1) = p$$

Which one of the following options is correct based on the above?

- (a) $f(2, 2) = g(2, 2)$
- (b) $f(g(2, 2), 2) < f(2, g(2, 2))$
- (c) $g(2, 1) \neq f(2, 1)$
- (d) $f(3, 2) > g(3, 2)$

Ans. (a)

Given: $f(p, q) = p^q$, $g(p, q) = p^{\overbrace{p \times p \times p \times \dots \times p}^{\text{(upto to } q \text{ terms)}}$

Here,

$$\begin{aligned} f(2, 2) &= 2^2 = 4 \\ f(2, 1) &= 2^1 = 2 \\ f(3, 2) &= 3^2 = 9 \\ g(2, 2) &= 2^2 = 4 \\ g(2, 1) &= 2 = 2 \\ g(3, 2) &= 3^3 = 9 \end{aligned}$$

Also,

$$\begin{aligned} f(g(2, 2), 2) &= f(4, 2) = 4^2 = 16 \\ f(2, g(2, 2)) &= f(2, 4) = 2^4 = 16 \end{aligned}$$

On checking options, the correct option is (a).

End of Solution

- Q.9** Four cities P , Q , R and S are connected through one-way routes as shown in the figure. The travel time between any two connected cities is one hour. The boxes beside each city name describe the starting time of first train of the day and their frequency of operation. For example, from city P , the first trains of the day start at 8 AM with a frequency of 90 minutes to each of R and S . A person does not spend additional time at any city other than the waiting time for the next connecting train. If the person starts from R at 7 AM and is required to visit S and return to R , what is the minimum time required?

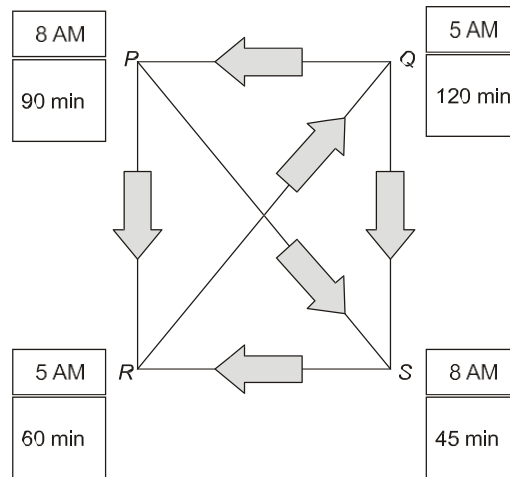

- (a) 6 hours 30 minutes
 (b) 3 hours 45 minutes
 (c) 4 hours 30 minutes
 (d) 5 hours 15 minutes

Ans. (a)

The person starts from R at 7 AM and visits S and then return to R , if he follows the routes $R \rightarrow Q \rightarrow P \rightarrow S \rightarrow R$.

Since, travel time between any two connected cities is one hour, the total travel time for the route will be 4 hours as shown below.

$$R \xrightarrow{+1} Q \xrightarrow{+1} P \xrightarrow{+1} S \xrightarrow{+1} R$$

Now, the person reaches the city Q at 8 AM but the next train is at 9 AM. At 9 AM, he starts from Q and reaches P at 10 AM. The next train at P is at 11 AM, hence the waiting time at P is 1 hour

He starts from P at 11 AM and reaches S at 12 AM but the next train at S is at 1:30 PM. Hence, waiting time at R is 1 hour and 30 Minutes.

Thus, the minimum time required is 6 hours 30 minutes.

End of Solution

Q.10 Equal sized circular regions are shaded in a square sheet of paper of 1 cm side length. Two cases, case *M* and case *N*, are considered as shown in the figures below. In the case *M*, four circles are shaded in the square sheet and in the case *N*, nine circles are shaded in the square sheet as shown.

What is the ratio of the areas of unshaded regions of case *M* to that of case *N*?

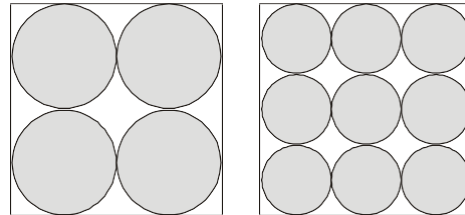

Case M

Case N

(a) 2 : 3

(b) 1 : 1

(c) 3 : 2

(d) 2 : 1

Ans. (b)

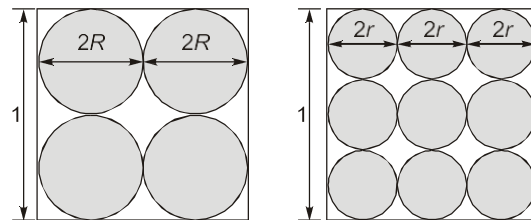

Case M

Case N

Here, $6r = 1$ and $4R = 1$

$$\Rightarrow r = \frac{1}{6} \text{ and } R = \frac{1}{4}$$

Area of square in case *M* = Area of square in case *N* = 1 cm²

$$\text{Total area of all circles in case M} = 4(\pi R^2) = 4\pi \times \left(\frac{1}{4}\right)^2 = \frac{\pi}{4} \text{ cm}^2$$

$$\text{Total area of all circles in case N} = 9(\pi r^2) = 9\pi \times \left(\frac{1}{6}\right)^2 = \frac{\pi}{4} \text{ cm}^2$$

$$\text{Thus, area of unshaded region in case M, } A_1 = \left(1 - \frac{\pi}{4}\right) \text{ cm}^2$$

$$\text{Thus, area of unshaded region in case N, } A_2 = \left(1 - \frac{\pi}{4}\right) \text{ cm}^2$$

Thus, the required ratio is

$$\frac{A_1}{A_2} = \frac{1 - \frac{\pi}{4}}{1 - \frac{\pi}{4}} = 1:1$$

End of Solution



SECTION - B

TECHNICAL

- Q.11** $F(t)$ is a periodic square wave function as shown. It takes only two values, 4 and 0, and stays at each of these values for 1 second before changing. What is the constant term in the Fourier series expansion of $F(t)$?

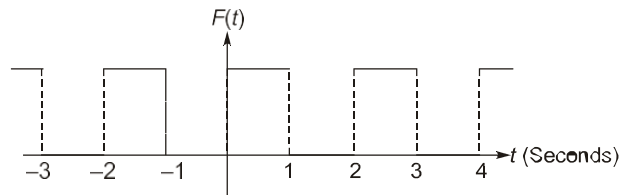

- (a) 1
(b) 2
(c) 3
(d) 4

Ans. (b)

Constant term in Fourier series is given by $\frac{a_0}{2}$.

$$\text{Where, } a_0 = \frac{1}{L} \int_0^L f(x) dx = \frac{1}{2} \int_0^2 f(x) dx$$

where $L = 1$ and period $[0, 2]$

$$\begin{aligned} &= 1 \times \text{Area under the curve within } [0, 2] \\ &= 1 \times 4 = 4 \end{aligned}$$

$$\text{Thus, } \frac{a_0}{2} = \frac{4}{2} = 2$$

End of Solution

- Q.12** Consider a cube of unit edge length and sides parallel to coordinate axes with its centroid at the point $(1, 2, 3)$. The surface integral $\int_A \vec{F} \cdot d\vec{A}$ of a vector field, $\vec{F} = 3x\hat{i} + 5y\hat{j} + 6z\hat{k}$

over the entire surface A area of the cube is _____.

- (a) 14
(b) 27
(c) 28
(d) 31

Ans. (a)

$$\text{Given: } \vec{F} = 3x\hat{i} + 5y\hat{j} + 6z\hat{k}$$

$$\vec{\nabla} \cdot \vec{F} = \frac{\partial}{\partial x}(3x) + \frac{\partial}{\partial y}(5y) + \frac{\partial}{\partial z}(6z) = 3 + 5 + 6 = 14$$

\therefore By Gauss' divergence theorem,

$$\begin{aligned} \int_A F dA &= \iiint_V \vec{\nabla} \cdot \vec{F} dV = \iiint_V 14 dV \\ &= 14 \times \text{Volume of cube} = 14 \times 1^3 = 14 \end{aligned}$$

End of Solution

Q.13 Consider the definite integral

$$\int_1^2 (4x^2 + 2x + 6) dx$$

Let I_e be the exact value of the integral. If the same integral is estimated using Simpson's rule with 10 equal subintervals, the value is I_s . The percentage error is defined as

$$e = 100 \times \frac{(I_e - I_s)}{I_e}. \text{ The value of } e \text{ is}$$

- (a) 2.5 (b) 3.5
(c) 1.2 (d) 0

Ans. (d)

Since the function $f(x) = 4x^2 + 2x + 6$ is a second degree polynomial and the Simpson's 1/3 rule also uses a second degree polynomial for approximation, the values of I_s and I_e will be same.

$$\therefore e = \frac{I_e - I_s}{I_e} \times 100 = 0$$

End of Solution

Q.14 Given $\int_{-\infty}^{\infty} e^{-x^2} dx = \sqrt{\pi}$. If a and b are integers, the value of $\int_{-\infty}^{\infty} e^{-a(x+b)^2} dx$ is _____.

- (a) $\sqrt{a\pi}$ (b) $\sqrt{\frac{\pi}{a}}$
(c) $b\sqrt{\pi a}$ (d) $b\sqrt{\frac{\pi}{a}}$

Ans. (b)

$$\begin{aligned} \text{Let } (x + b) &= t \\ \Rightarrow dx &= dt \end{aligned}$$

When, $x = -\infty$; $t = -\infty$
and, $x = \infty$; $t = \infty$

$$\therefore \int_{-\infty}^{\infty} e^{-a(x+b)^2} dx = \int_{-\infty}^{\infty} e^{-at^2} dt$$

$$\text{Now, let, } at^2 = y^2 \Rightarrow t = \frac{y}{\sqrt{a}}$$

$$\Rightarrow 2at dt = 2y dy$$

$$\Rightarrow dt = \frac{y dy}{at} = \frac{y dy}{ay} = \frac{dy}{\sqrt{a}}$$

$$\therefore \int_{-\infty}^{\infty} e^{-at^2} dt = \int_{-\infty}^{\infty} e^{-y^2} \cdot \frac{dy}{\sqrt{a}} = \frac{1}{\sqrt{a}} \int_{-\infty}^{\infty} e^{-y^2} dy = \frac{\sqrt{\pi}}{\sqrt{a}}$$

End of Solution

Q.15 A polynomial $\phi(s) = a_n s^n + a_{n-1} s^{n-1} + \dots + a_1 s + a_0$ of degree $n > 3$ with constant real coefficients a_n, a_{n-1}, \dots, a_0 has triple roots at $s = -\sigma$. Which one of the following conditions must be satisfied?

(a) $\phi(s) = 0$ at all the three values of s satisfying $s^3 + \sigma^3 = 0$

(b) $\phi(s) = 0, \frac{d\phi(s)}{ds} = 0, \text{ and } \frac{d^2\phi(s)}{ds^2} = 0$ at $s = -\sigma$

(c) $\phi(s) = 0, \frac{d^2\phi(s)}{ds^2} = 0, \text{ and } \frac{d^4\phi(s)}{ds^4} = 0$ at $s = -\sigma$

(d) $\phi(s) = 0, \text{ and } \frac{d^3\phi(s)}{ds^3} = 0$ at $s = -\sigma$

Ans. (b)

Since, $\phi(s)$ has triple roots at $s = -\sigma$, $(s + \sigma)^3$ will be one of its factors and $\phi(-\sigma) = 0$. There will be an inflection point on the curve of $\phi(s)$ (just like in the case of x^3). Hence, the first and second order derivative at $s = -\sigma$ will be zero.

End of Solution

Q.16 Which one of the following is the definition of ultimate tensile strength (UTS) obtained from a stress-strain test on a metal specimen?

(a) Stress value where the stress-strain curve transitions from elastic to plastic behavior.

(b) The maximum load attained divided by the original cross-sectional area.

(c) The maximum load attained divided by the corresponding instantaneous cross-sectional area.

(d) Stress where the specimen fractures.

Ans. (b)

U.T.S. (Ultimate tensile strength) from tension test is given by

$$S_{ut} = \frac{\text{Maximum load}}{\text{Original cross-sectional area}}$$

End of Solution

Q.17 A massive uniform rigid circular disc is mounted on a frictionless bearing at the end E of a massive uniform rigid shaft AE which is suspended horizontally in a uniform gravitational field by two identical light inextensible strings AB and CD as shown, where G is the center of mass of the shaft-disc assembly and g is the acceleration due to gravity. The disc is then given a rapid spin ω about its axis in the positive x -axis direction as shown, while the shaft remains at rest. The direction of rotation is defined by using the right-hand thumb rule. If the string AB is suddenly cut, assuming negligible energy dissipation, the shaft AE will

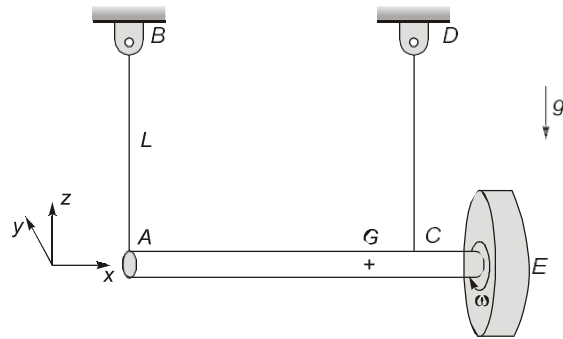

- (a) rotate slowly (compared to ω) about the negative z-axis direction
- (b) rotate slowly (compared to ω) about the positive z-axis direction
- (c) rotate slowly (compared to ω) about the positive y-axis direction
- (d) rotate slowly (compared to ω) about the negative y-axis direction

Ans. (a)

As centre of mass is in between strings AB and CD so due to gyroscopic effect it rotates about the negative z-axis direction as it is rotating clockwise when viewed from the top.

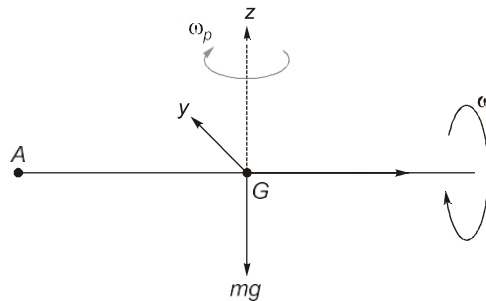

End of Solution

Q.18 A structural member under loading has a uniform state of plane stress which in usual notations is given by $\sigma_x = 3P$, $\sigma_y = -2P$ and $\tau_{xy} = \sqrt{2}P$, where $P > 0$. The yield strength of the material is 350 MPa. If the member is designed using the maximum distortion energy theory, then the value of P at which yielding starts (according to the maximum distortion energy theory) is

- (a) 70 MPa
- (b) 90 MPa
- (c) 120 MPa
- (d) 75 MPa

Ans. (a)

$$\text{Principal stresses, } \sigma_{1,2} = \frac{1}{2} \left[(3P - 2P) \pm \sqrt{(3P + 2P)^2 + 4 \times (\sqrt{2}P)^2} \right]$$

$$\sigma_{1,2} = 3.375 P, -2.375 P$$

So by MDET

$$\sigma_1^2 + \sigma_2^2 - \sigma_1\sigma_2 = \left(\frac{S_{yt}}{N}\right)^2$$

$$(3.375P)^2 + (-2.375P)^2 - [3.375P \times (-2.375P)] = (350)^2 \quad [\because N = 1]$$

$$\Rightarrow P = 70.06 \text{ N}$$

End of Solution

- Q.19** Fluidity of a molten alloy during sand casting depends on its solidification range. The phase diagram of a hypothetical binary alloy of components A and B is shown in the figure with its eutectic composition and temperature. All the lines in this phase diagram, including the solidus and liquidus lines, are straight lines. If this binary alloy with 15 weight % of B is poured into a mould at a pouring temperature of 800 °C, then the solidification range is

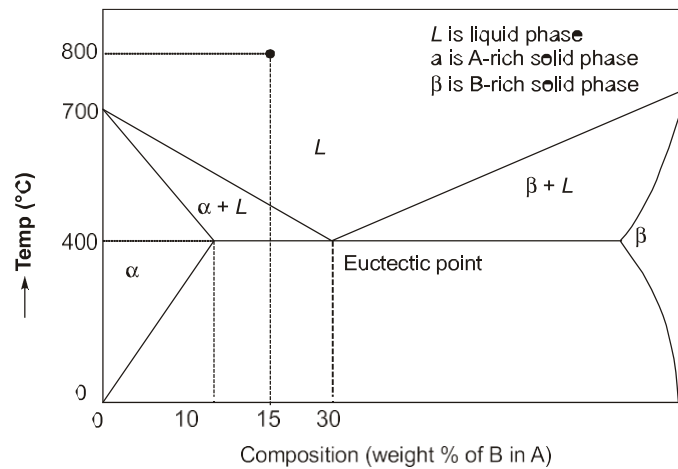

- (a) 400°C
(b) 250°C
(c) 800°C
(d) 150°C

Ans. (d)

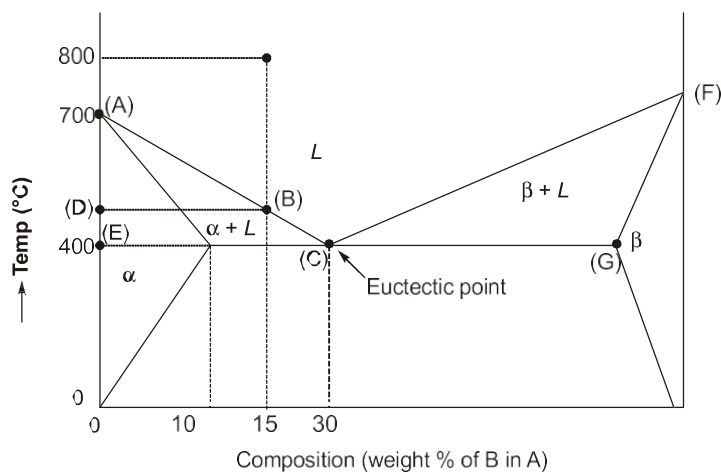

By similar triangles ABD and ACE :

$$\frac{AD}{AE} = \frac{DB}{CE}$$

$$\Rightarrow AD = \frac{15}{30} \times 300 = 150$$

$$\Rightarrow DE = 300 - 150 = 150^\circ\text{C}$$

End of Solution

Q.20 A shaft of diameter $25_{-0.07}^{0.04}$ mm is assembled in a hole of diameter $25_{-0.00}^{0.02}$ mm. Match the allowance and limit parameter in **Column I** with its corresponding quantitative value in **Column II** for this shaft-hole assembly.

Column-I

Column-II

- | | |
|-----------------------------------|-------------|
| P. Allowance | 1. 0.09 mm |
| Q. Maximum clearance | 2. 24.96 mm |
| R. Maximum material limit of hole | 3. 0.04 mm |
| | 4. 25 mm |

- (a) P-3, Q-1, R-4
 (b) P-1, Q-3, R-2
 (c) P-1, Q-3, R-4
 (d) P-3, Q-3, R-2

Ans. (a)

Given: Shaft: $25_{-0.07}^{0.04}$ and Hole = $25_{-0.00}^{0.02}$

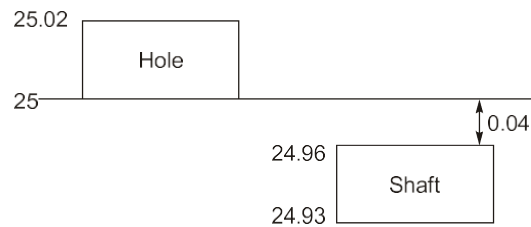

Allowance is the difference in the maximum material limit of hole and shaft.

- Allowance = Max. material limit
 $= 25 - 24.96 = 0.04$ mm
- Max. clearance = Hole_{max} - Shaft_{min}
 $= 25.02 - 24.93 = 0.09$ mm
- Maximum material limit of hole = Minimum size of hole = 25 mm

So, $\begin{matrix} P-3 \\ Q-1 \\ R-4 \end{matrix}$

End of Solution

Q.21 Match the additive manufacturing technique in **Column I** with its corresponding input material in **Column II**.

Column-I

- P. Fused deposition modelling
- Q. laminated object manufacturing
- R. Selective laser sintering

Column-II

- 1. Photo sensitive liquid resin
- 2. Heat fusible powder
- 3. Filament of polymer
- 4. Sheet of thermoplastic or green compacted metal sheet

- (a) P-3, Q-4, R-2
- (b) P-1, Q-2, R-4
- (c) P-2, Q-3, R-1
- (d) P-4, Q-1, R-4

Ans. (a)

End of Solution

Q.22 Which one of the following CANNOT impart linear motion in a CNC machine?

- (a) Linear motor
- (b) Ball screw
- (c) Lead screw
- (d) Chain and sprocket

Ans. (d)

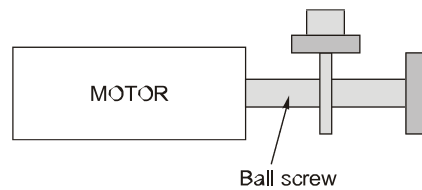

Except chain and sprocket all can impart linear motion in a CNC machine.
So, option (b) is correct.

End of Solution

Q.23 Which one of the following is an intensive property of a thermodynamic system?

- (a) Mass
- (b) Density
- (c) Energy
- (d) Volume

Ans. (b)

As Density, $\rho = \frac{\text{Mass}}{\text{Volume}}$

End of Solution

- Q.24** Consider a steady flow through a horizontal divergent channel, as shown in the figure, with supersonic flow at the inlet. The direction of flow is from left to right.

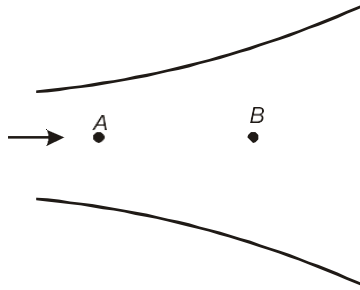

Pressure at location B is observed to be higher than that at an upstream location A. Which among the following options can be the reason?

- (a) Since volume flow rate is constant, velocity at B is lower than velocity at A
- (b) Normal shock
- (c) Viscous effect
- (d) Boundary layer separation

Ans. (b)

Since this is horizontal divergent channel with supersonic flow at inlet so if normal flow occurs, it acts as a nozzle.

So, V_B should be greater than V_A and P_B should be lesser than P_A .

If we found out $P_B > P_A$ so there should be a normal shock available.

End of Solution

- Q.25** Which of the following non-dimensional terms is an estimate of Nusselt number?
- (a) Ratio of internal thermal resistance of a solid to the boundary layer thermal resistance.
 - (b) Ratio of the rate at which internal energy is advected to the rate of conduction heat transfer.
 - (c) Non-dimensional temperature gradient.
 - (d) Non-dimensional velocity gradient multiplied by Prandtl number.

Ans. (c)

$$\text{Nusselt number, } Nu = \frac{hD}{k_{\text{fluid}}}$$

$$Nu = \frac{Q_{\text{conv.}}}{Q_{\text{cond.}}} = \frac{\text{Conduction thermal resistance offered by fluid if it were stationary}}{\text{Surface convection thermal resistance}}$$

End of Solution

- Q.26** A square plate is supported in four different ways (configurations (P) to (S) as shown in the figure). A couple moment C is applied on the plate. Assume all the members to be rigid and mass-less, and all joints to be frictionless. All support links of the plate are identical.

Q.28 Which of these processes involve(s) melting in metallic workpieces?

- (a) Electrochemical machining
- (b) Electric discharge machining
- (c) Laser beam machining
- (d) Electron beam machining

Ans. (b, c, d)

For thermal methods mechanism will be same → Melting, fusion and vaporisation. So, except ECM all involves melting of metal workpieces.

End of Solution

Q.29 The velocity field in a fluid is given to be $\vec{V} = (4xy)\hat{i} + 2(x^2 - y^2)\hat{j}$. Which of the following statement(s) is/are correct?

- (a) The velocity field is one-dimensional.
- (b) The flow is incompressible.
- (c) The flow is irrotational.
- (d) The acceleration experienced by a fluid particle is zero at $(x = 0, y = 0)$.

Ans. (b, c, d)

Given: $U = 4xy, V = 2(x^2 - y^2)$

(i) For incompressible flow,

$$\vec{\nabla} \cdot \vec{V} = 0$$

Here,

$$\nabla \cdot \vec{V} = \frac{\partial U}{\partial x} + \frac{\partial V}{\partial y} = 4y - 4y = 0$$

So, fluid is incompressible.

(ii) For irrotational flow,

$$\omega_z = 0$$

Here,

$$\omega_z = \frac{1}{2} \left(\frac{\partial v}{\partial x} - \frac{\partial u}{\partial y} \right) = \frac{1}{2} (4x - 4x) = 0$$

So, fluid is irrotational.

(iii) Acceleration at $x = 0, y = 0$

$$a_x = \frac{Du}{Dt} = \left[u \frac{\partial u}{\partial x} + v \frac{\partial u}{\partial y} \right]_{(x=0, y=0)} = [0 \times 0 + 0 \times 0] = 0$$

$$a_y = \frac{Dv}{Dt} = \left[u \frac{\partial v}{\partial x} + v \frac{\partial v}{\partial y} \right]_{(x=0, y=0)} = [0 \times 0 + 0 \times 0] = 0$$

So, acceleration of fluid at $x = 0, y = 0$ is zero.

It is a 2-D flow.

End of Solution

Q.30 A rope with two mass-less platforms at its two ends passes over a fixed pulley as shown in the figure. Discs with narrow slots and having equal weight of 20 N each can be placed on the platforms. The number of discs placed on the left side platform is n and that on the right side platform is m .

It is found that for $n = 5$ and $m = 0$, a force $F = 200$ N (refer to part (i) of the figure) is just sufficient to initiate upward motion of the left side platform. If the force F is removed then the minimum value of m (refer to part (ii) of the figure) required to prevent downward motion of the left side platform is _____ (in integer).

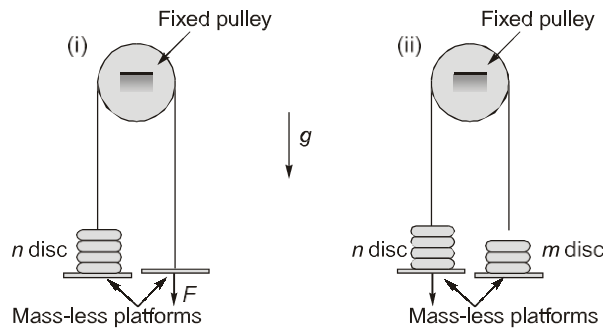

Ans. (3) (3 to 3)

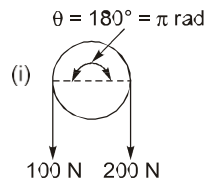

So,

$$\frac{T_1}{T_2} = e^{\mu\theta}$$

$$\frac{200}{100} = e^{\mu\theta}$$

$$\Rightarrow \mu = 0.22$$

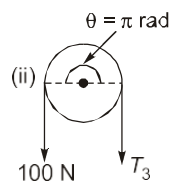

Now,

$$\frac{200}{T_3} = e^{0.22\pi}$$

$$\Rightarrow T_3 = \frac{100}{2} = 50 \text{ N}$$

So, for 50 N number of discs = $\frac{50}{20} = 2.5$

So, minimum number of disc required are 3.

End of Solution

Q.31 For a dynamical system governed by the equation,

$$\ddot{x}(t) + (2\xi\omega_n)\dot{x}(t) + (\omega_n^2)x(t) = 0$$

the damping ratio ξ is equal to $\frac{1}{2\pi}\log_e(2)$. The displacement x of this system is measured during a hammer test. A displacement peak in the positive displacement direction is measured to be 4 mm. Neglecting higher powers (> 1) of the damping ratio, the displacement at the next peak in the positive direction will be _____ mm (in integer).

Ans. (2) (2 to 2)

Equation of damped system,

$$\ddot{x} + (2\xi\omega_n)\dot{x} + (\omega_n^2)x = 0$$

Where, ξ = Damping factor

$$\text{Given: } \xi = \frac{1}{2\pi}\log_e 2 = 0.1103178$$

Initial peak displacement = 4 mm

So, for next peak displacement As $\xi < 1$

\Rightarrow This is an under damped system logarithmic decrement,

$$\delta = \frac{2\pi\xi}{\sqrt{1-\xi^2}} = 0.6974$$

Decrement ratio:

$$\frac{x_0}{x_1} = \frac{x_1}{x_2} = \frac{x_2}{x_3} \dots = e^\delta$$

$$\frac{x_0}{x_1} = e^{0.6974}$$

$$x_1 = \frac{x_0}{e^{0.6974}} = \frac{4}{2.0085} = 1.991 \text{ mm} \simeq 2 \text{ mm}$$

End of Solution

Q.32 An electric car manufacturer underestimated the January sales of car by 20 units, while the actual sales was 120 units. If the manufacturer uses exponential smoothening method with a smoothing constant of $\alpha = 0.2$, then the sales forecast for the month of February of the same year is _____ units (in integer).

Ans. (104) (104 to 104)

Given: $\alpha = 0.1$, Demand, $D_{\text{Jan}} = 120$, Forecast, $F_{\text{Jan}} = 100$

So, error, $e_{\text{Jan}} = 20$

We know that, $F_t = F_{t-1} + \alpha e_{t-1}$
 $= 100 + 0.2 \times 20 = 104$ units

End of Solution

Q.33 The demand of a certain part is 1000 parts/year and its cost is ₹1000/part. The orders are placed based on the economic order quantity (EOQ). The cost of ordering is ₹100/order and the lead time for receiving the orders is 5 days. If the holding cost is ₹20/part/year, the inventory level for placing the orders is _____ parts. (round off to the nearest integer)

Ans. (14) (13 to 15)

Given: Demand, $D = 1000$ parts/year, Cost, $C = ₹1000$ per part

Ordering cost, $C_o = ₹100$ per order

Lead time, $LT = 5$ days

Holding cost, $C_h = ₹20$ per part per year

Inventory level for placing orders = $LT \times \text{Demand per day} = \frac{LT \times D}{365}$

Assuming 365 days in a year.

So,
$$\text{ROL} = \frac{5 \times 1000}{365} = 13.698 \approx 14 \text{ parts}$$

End of Solution

Q.34 Consider 1 kg of an ideal gas at 1 bar, 300 K contained in a rigid and perfectly insulated container. The specific heat of the gas at constant volume, C_v is equal to $750 \text{ Jkg}^{-1}\text{K}^{-1}$. A stirrer performs 225 kJ of work on gas. Assume that the container does not participate in the thermodynamic interaction. The final pressure of the gas will be ____ bar (in integer).

Ans. (2) (2 to 2)

Given: $C_v = 750 \text{ J/kgK} = 0.75 \text{ kJ/kgK}$, $m = 1 \text{ kg}$

By first law of thermodynamics

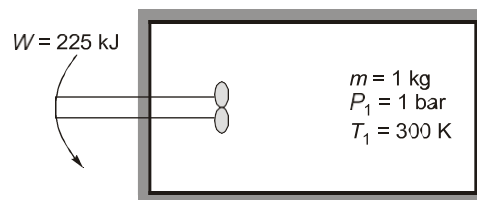

$$Q = \Delta U + W$$

$$0 = mC_v(T_2 - 300) + (-225)$$

$$T_2 = \frac{225}{1 \times 0.75} + 300 = 600 \text{ K}$$

Since air can be considered as an ideal gas,

$$PV = mRT$$

$$P \propto T$$

[$\because V = \text{Constant}$]

$$\frac{P_2}{P_1} = \frac{T_2}{T_1}$$

$$P_2 = \frac{600}{300} \times 1 \text{ bar} = 2 \text{ bar}$$

End of Solution

- Q.35** Wien's law is stated as follows: $\lambda_m T = C$, where C is $2898 \mu\text{m}\cdot\text{K}$ and λ_m is the wavelength at which the emissive power of a black body is maximum for a given temperature T . The spectral hemispherical emissivity (ϵ_λ) of a surface is shown in the figure below ($1\text{\AA} = 10^{-10}\text{m}$). The temperature at which the total hemispherical emissivity will be highest is _____ K (round off to the nearest integer).

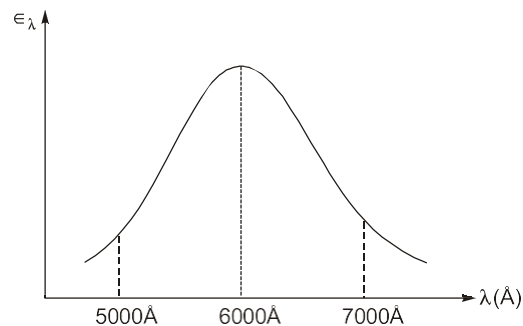

Ans. (4830) (4825 to 4835)

As we know that $\epsilon_\lambda = \frac{E_\lambda}{E_{b\lambda}}$

From Wien's displacement law

$$\lambda_m T = \text{Constant} = 2898 \mu\text{m}\cdot\text{K}$$

So,
$$\frac{6000 \times 10^{-10}}{10^{-6}} \times T = 2898 \quad [1 \mu = 10^{-6} \text{ m}]$$

$$T = 4830 \text{ K}$$

End of Solution

- Q.36** For the exact differential equation,

$$\frac{du}{dx} = \frac{-xu^2}{2+x^2u}$$

Which one of the following is the solution?

- (a) $u^2 + 2x^2 = \text{Constant}$ (b) $xu^2 + u = \text{Constant}$
 (c) $\frac{1}{2}x^2u^2 + 2u = \text{Constant}$ (d) $\frac{1}{2}ux^2 + 2x = \text{Constant}$

Ans. (c)

Given differential equation,

$$\frac{du}{dx} = \frac{-xu^2}{2+x^2u}$$

Rewriting it as,

$$(2+x^2u)du + (xu^2)dx = 0$$

Checking for exactness,

$$\frac{\partial M}{\partial u} = \frac{\partial}{\partial u}(xu^2) = 2xu$$

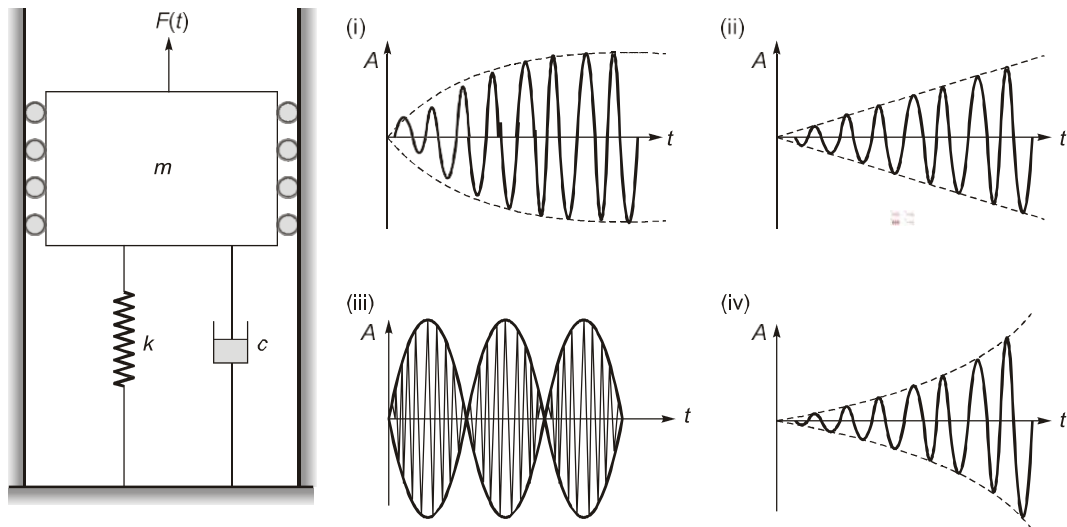

Four different parameter and forcing conditions are mentioned below.

P. $c > 0$ and $\omega = \sqrt{\frac{k}{m}}$

Q. $c < 0$ and $\omega \neq 0$

R. $c = 0$ and $\omega = \sqrt{\frac{k}{m}}$

S. $c = 0$ and $\omega \cong \sqrt{\frac{k}{m}}$

(a) P-(i), Q-(iii), R-(iv), S-(ii)

(b) P-(ii), Q-(iii), R-(iv), S-(i)

(c) P-(i), Q-(iv), R-(ii), S-(iii)

(d) P-(iii), Q-(iv), R-(ii), S-(i)

Ans. (c)

$$x = (A_1 \sin \omega_n t + A_2 \cos \omega_n t) + \frac{(F_0/k)}{\left(1 - \left(\frac{\omega}{\omega_n}\right)^2\right)} \cos \omega t$$

At

$$\omega = \sqrt{\frac{k}{m}} = \omega_n$$

$$\frac{\omega}{\omega_n} = 1$$

$$x = (A_1 \sin \omega_n t + A_2 \cos \omega_n t) + \frac{(F_0/k)}{2m\omega_n} \sin \omega_n t$$

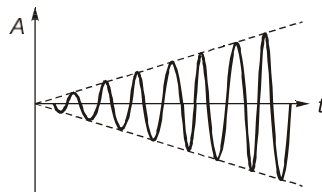

R - (ii)

S - (iii)

This implies option (c) is correct.

End of Solution

Q.42 A manufacturing unit produces two products P1 and P2. For each piece of P1 and P2, the table below provides quantities of materials M1, M2, and M3 required, and also the profit earned. The maximum quantity available per day for M1, M2 and M3 is also provided. The maximum possible profit per day is ₹_____.

	M1	M2	M3	Profit per piece (₹)
P_1	2	2	0	150
P_2	3	1	2	100
Maximum quantity available per day	70	50	40	

- (a) 5000
(c) 3000

- (b) 4000
(d) 6000

Ans. (b)

	M1	M2	M3	Profit per piece (₹)
P_1	2	2	0	150
P_2	3	1	2	100
Maximum quantity available per day	70	50	40	

$$2X_1 + 3X_2 \leq 70 \quad \dots \text{(i)}$$

$$2X_1 + X_2 \leq 50 \quad \dots \text{(ii)}$$

$$2X_2 \leq 40 \quad \dots \text{(iii)}$$

$$\text{Max. } Z = 150X_1 + 100X_2$$

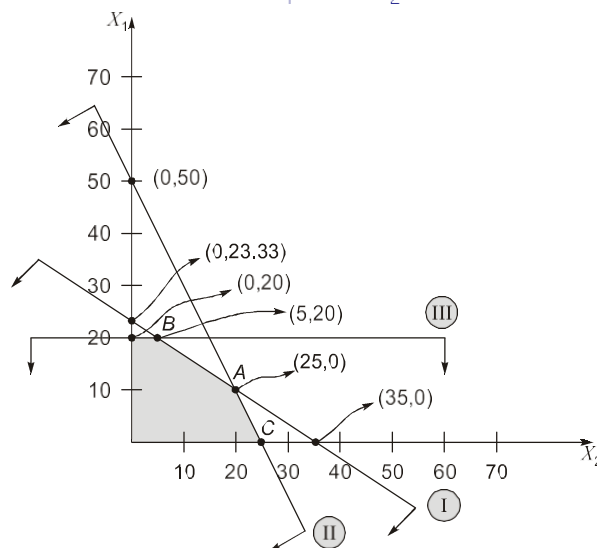

Solution of equation (i) and (iii) gives point (B)

$$2X_1 + 3 \times 20 = 70$$

$$X_1 = \frac{70 - 60}{2} = 5$$

So, point coordinate of B is (5, 20)

Solution of equation (i) and (ii) gives point A

$$(50 - X_2) + 2X_2 = 70$$

$$50 + 2X_2 = 70$$

$$X_2 = 10$$

$$\Rightarrow X_1 = \frac{50 - 10}{2} = 20$$

So, point coordinate of A is (20, 10)

$$\text{At point A, } Z = 150 \times 20 + 100 \times 10 = ₹4000$$

$$\text{At point B, } Z = 150 \times 5 + 100 \times 20 = ₹2750$$

$$\text{At point C, } Z = 150 \times 25 + 100 \times 0 = ₹3750$$

So, maximum profit per day is ₹4000.

End of Solution

Q.43 A tube of uniform diameter D is immersed in a steady flowing inviscid liquid stream of velocity V , as shown in the figure. Gravitational acceleration is represented by g . The volume flow rate through the tube is _____.

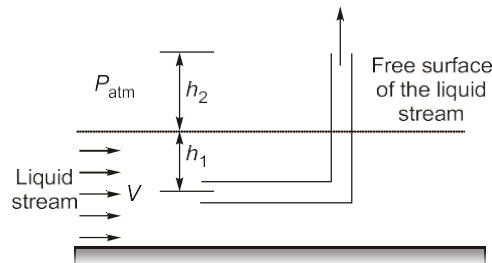

(a) $\frac{\pi}{4} D^2 V$

(b) $\frac{\pi}{4} D^2 \sqrt{2gh_2}$

(c) $\frac{\pi}{4} D^2 \sqrt{2g(h_1 + h_2)}$

(d) $\frac{\pi}{4} D^2 \sqrt{V^2 - 2gh_2}$

Ans. (d)

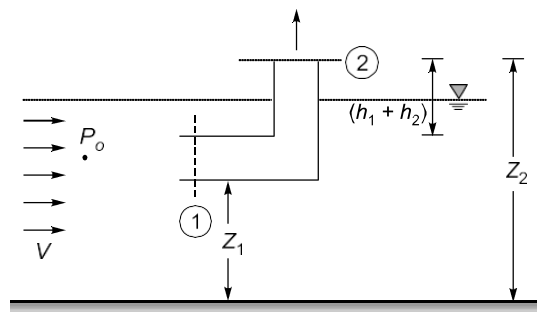

By Bernoulli's equation between point 1 and 2

$$\frac{P_1}{\rho g} + \frac{V_1^2}{2g} + Z_1 = \frac{P_2}{\rho g} + \frac{V_2^2}{2g} + Z_2$$

$$\frac{P_1}{\rho g} + Z_1 = 0 + Z_2$$

$$[\because A_1 = A_2 \Rightarrow V_1 = V_2]$$

$$x = \frac{50}{200} \Rightarrow x = 0.25$$

End of Solution

Q.46 A is a 3×5 real matrix of rank 2. For the set of homogeneous equations $Ax = 0$, where 0 is a zero vector and x is a vector of unknown variables, which of the following is/are true?

- (a) The given set of equations will have a unique solution.
- (b) The given set of equations will be satisfied by a zero vector of appropriate size.
- (c) The given set of equations will have infinitely many solutions.
- (d) The given set of equations will have many but a finite number of solutions.

Ans. (b, c)

Given: $\rho(A) = 2$

Since the rank of matrix A is less than the number of variables, so there will be infinitely many solutions including a zero vector of appropriate size.

End of Solution

Q.47 The lengths of members BC and CE in the frame shown in the figure are equal. All the members are rigid and lightweight, and the friction at the joints is negligible. Two forces of magnitude $Q > 0$ are applied as shown, each at the mid-length of the respective member on which it acts.

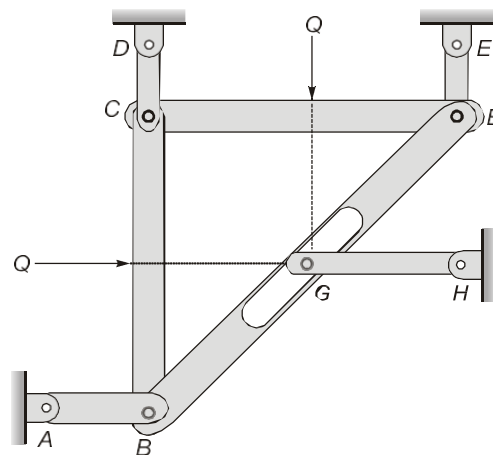

Which one or more of the following members do not carry any load (force)?

- (a) AB
- (b) CD
- (c) EF
- (d) GH

Ans. (b, d)

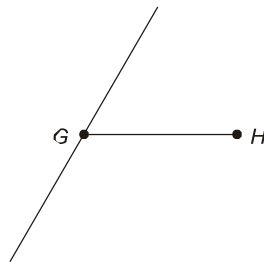

If at a joint 3 members are meeting and two are colinear then in 3rd member force will be zero.

$$F_{GH} = 0$$

End of Solution

Q.48 If the sum and product of eigen values of a 2×2 matrix $\begin{bmatrix} 3 & p \\ p & q \end{bmatrix}$ are 4 and -1 respectively, then $|p|$ is _____ (in integer).

Ans. (2) (2 to 2)

From properties of eigen values,

1. Sum of eigen values = Trace of matrix

$$\Rightarrow 4 = 3 + q$$

$$\text{or } q = 1$$

2. Product of eigen values = Determinant

$$\Rightarrow -1 = \begin{vmatrix} 3 & p \\ p & q \end{vmatrix}$$

$$\Rightarrow 3q - p^2 = -1$$

$$\Rightarrow 3 - p^2 = -1$$

$$\Rightarrow p^2 = 4$$

$$\Rightarrow p = \pm 2$$

Thus, $|p| = 2$

End of Solution

Q.49 Given $z = x + iy$, $i = \sqrt{-1}$. C is a circle of radius 2 with the centre at the origin. If the

contour C is traversed anticlockwise, then the value of the integral $\frac{1}{2\pi} \int_C \frac{1}{(z-i)(z+4i)} dz$

is _____ (round off to one decimal place).

Ans. (0.2) (0.2 to 0.2)

$$\text{Let, } f(z) = \frac{1}{(z-i)(z+4i)}$$

Singular points : $z = i, -4i$

Since C is circle of radius 2, only $z = i$ will lie inside the circle.

$$\text{Thus, } \oint_C f(z) dz = 2\pi i (\text{Res}|_{z=i})$$

$$\text{where, } \text{Res}|_{z=i} = \lim_{z \rightarrow i} (z-i)f(z) = \lim_{z \rightarrow i} \frac{1}{z+4i} = \frac{1}{5i}$$

$$\therefore \oint_C \frac{1}{(z-i)(z+4i)} dz = 2\pi i \left(\frac{1}{5i} \right) = \frac{2}{5} \pi$$

$$\text{or, } \frac{1}{2\pi} \oint_C \frac{1}{(z-i)(z+4i)} dz = \frac{1}{5} = 0.2$$

End of Solution

Q.50 A shaft of length L is made of two materials, one in the inner core and the other in the outer rim, and the two are perfectly joined together (no slip at the interface) along the entire length of the shaft. The diameter of the inner core is d_i and the external diameter of the rim is d_o , as shown in the figure. The modulus of rigidity of the core and rim materials are G_i and G_o , respectively. It is given that $d_o = 2d_i$ and $G_i = 3G_o$. When the shaft is twisted by application of a torque along the shaft axis, the maximum shear stress developed in the outer rim and the inner core turn out to be τ_o and τ_i , respectively. All the deformations are in the elastic range and stress-strain relations are linear. Then

the ratio $\frac{\tau_i}{\tau_o}$ is _____ (round off to 2 decimal places).

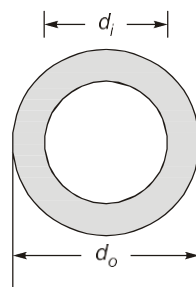

Shaft cross-section

Ans. (1.50) (1.48 to 1.52)

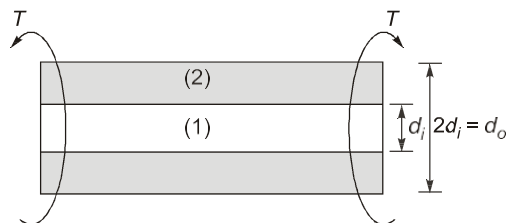

Given: $\frac{G_1}{G_2} = 3$, Let $d_i = d_1, \Rightarrow d_o = 2d_1$ and $\frac{(\tau_{\max})_1}{(\tau_{\max})_2} = ?$

As shaft are in parallel condition,

Angle of twist, $\theta_1 = \theta_2$

(Compatibility equation)

$$\frac{32T_1L_1}{G_1 \times \pi d_1^4} = \frac{32T_2L_2}{G_2 \times \pi d_2^4 (1-k^4)}$$

$$\frac{T_1}{T_2} = \frac{G_1 \left(\frac{d_1}{d_2}\right)^4 \left(\frac{1}{1-k^4}\right)}$$

$$= 3 \times \left(\frac{1}{2}\right)^4 \times \frac{1}{1-\left(\frac{1}{2}\right)^4} = \frac{3}{16} \times \frac{1}{1-\frac{1}{16}} = \frac{3}{16} \times \frac{16}{15}$$

$$\Rightarrow \frac{T_1}{T_2} = \frac{3}{15}$$

Now,
$$\frac{\tau_1}{\tau_2} = \frac{16T_1}{\pi d_1^3} \times \frac{\pi d_2^3}{16T_2} (1-k^4)$$

$$= \frac{3}{15} \times \left(\frac{2d}{d}\right)^3 \times \left(1-\left(\frac{1}{2}\right)^4\right)$$

$$= \frac{3}{15} \times 8 \times \frac{15}{16} = \frac{3}{2} = 1.5$$

End of Solution

- Q.51** A rigid beam AD of length $3a = 6$ m is hinged at frictionless pin joint A and supported by two strings as shown in the figure. String BC passes over two small frictionless pulleys of negligible radius. All the strings are made of the same material and have equal cross-sectional area. A force $F = 9$ kN is applied at C and the resulting stresses in the strings are within linear elastic limit. The self-weight of the beam is negligible with respect to the applied load. Assuming small deflections, the tension developed in the string at C is _____ kN (round off to 2 decimal places).

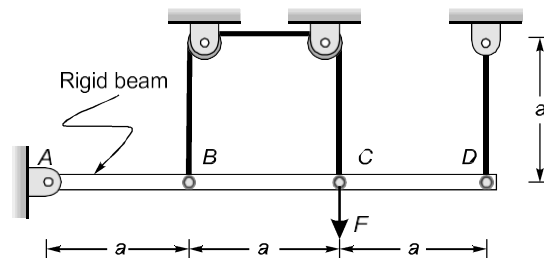

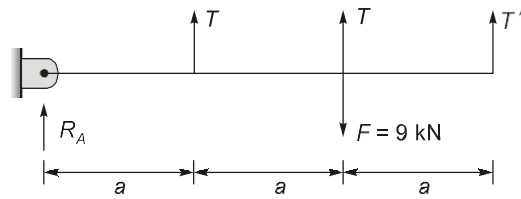

By force balancing and moment balancing:

$$\begin{aligned} \Sigma F_y &= 0 \\ R_A + 2T + T' &= 9 \end{aligned} \quad \dots(i)$$

$$\begin{aligned} \Sigma M_A &= 0 \\ T \times a + T \times 2a + T' \times 3a &= F \times 2a \\ 3Ta + 3T' a &= 18a \end{aligned}$$

$$T + T' = \frac{18}{3}$$

$$T + T' = 6 \quad \dots(ii)$$

for small deflections

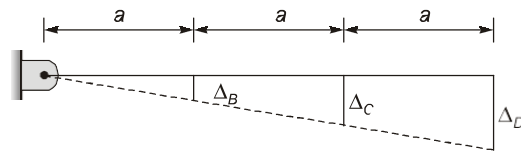

By similar triangles

$$\frac{\Delta_B}{a} = \frac{\Delta_C}{2a} = \frac{\Delta_D}{3a}$$

$$\Delta_B = \frac{\Delta_C}{2}; \quad \Delta_B = \frac{\Delta_D}{3} \quad \dots(iii)$$

As in rope BC it is stretching due to tension T length of rope BC $l_{BC} = 3a$

So, $\Delta_B + \Delta_C = \frac{T \times 3a}{AE}$ [Due to deflection wire stretched = $\Delta_B + \Delta_C$]

$$\Delta_B + 2\Delta_B = \frac{T \times 3a}{AE}$$

$$\Delta_B = \frac{Ta}{AE}$$

By equation (iii)

$$\frac{Ta}{AE} = \frac{T'a}{3AE}$$

$$T = \frac{T'}{3}$$

By equation (ii)

$$\frac{T'}{3} + T' = 6$$

$$\Rightarrow T' = \frac{6 \times 3}{4} = 4.5 \text{ kN}$$

$$\Rightarrow T = 6 - 4.5 = 1.5 \text{ kN}$$

End of Solution

Q.52 In the configuration of the planar four-bar mechanism at a certain instant as shown in the figure, the angular velocity of the 2 cm long link is $\omega_2 = 5 \text{ rad/s}$. Given the dimensions as shown, the magnitude of the angular velocity ω_4 of the 4 cm long link is given by ____ rad/s (round off to 2 decimal places).

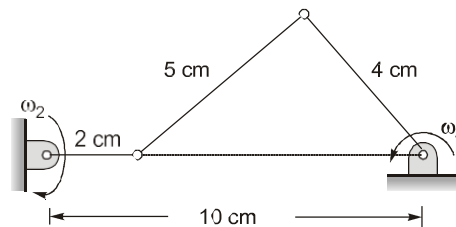

Ans. (1.25) (1.24 to 1.26)

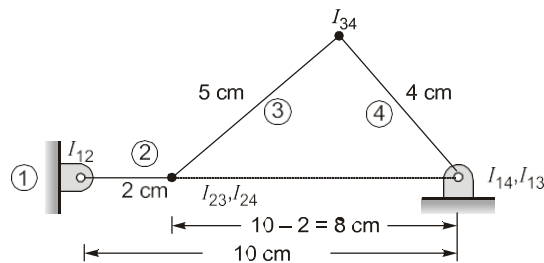

Applying angular velocity theorem at I_{24} :

$$\omega_2 (I_{24} I_{12}) = \omega_4 (I_{24} I_{14})$$

$$5 \times 2 = \omega_4 \times 8$$

$$\omega_4 = \frac{10}{8} = 1.25$$

$$\omega_4 = 1.25 \text{ rad/s}$$

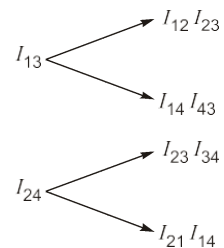
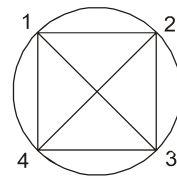

End of Solution

end C which drives a belt. A motor is coupled at the end A of the shaft such that it applies a torque M_z about the shaft axis without causing any bending moment. The shaft is mounted on narrow frictionless bearings at A and B where $AB = BC = L = 0.5$ m. The taut and slack side tensions of the belt are $T_1 = 300$ N and $T_2 = 100$ N, respectively. The allowable shear stress for the shaft material is 80 MPa. The self-weights of the pulley and the shaft are negligible. Use the value of π available in the on-screen virtual calculator. Neglecting shock and fatigue loading and assuming maximum shear stress theory, the minimum required shaft diameter is _____ mm (round off to 2 decimal places).

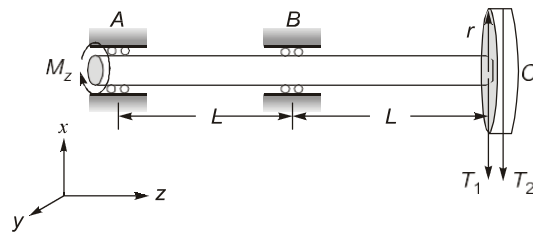

Ans. (23.94) (23.60 to 24.20)

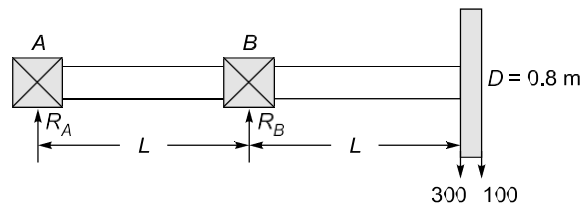

$$\begin{aligned} \text{Twisting moment, } T &= (T_1 - T_2)r \\ &= (300 - 100) \times 0.4 \\ &= 80 \text{ Nm} = 80 \times 10^3 \text{ N.mm} \end{aligned}$$

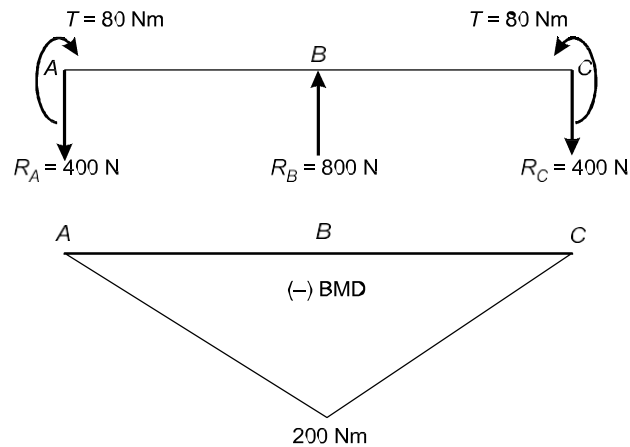

Note : As given in the question the bending moment due to motor is to be neglected but the bending moment due to reactions is to be considered.

$$\sum M_A = 0$$

$$\Rightarrow R_B \times (L) = 400 \times 2L$$

$$\Rightarrow R_B = 800 \text{ N } (\uparrow)$$

$$\sum V = 0$$

$$\Rightarrow R_A = 400 (\uparrow)$$

As per M.S.S.T.,

$$T_e \leq \left[T_R = \frac{\pi}{16} d^3 \tau_{per} \right]$$

$$\sqrt{(k_b M)^2 + (k_t T)^2} \leq \left(\frac{\pi}{16} \right) (d^3) (80 \times 10^6)$$

$$\sqrt{(1 \times 200)^2 + (1 \times 80)^2} \leq \frac{\pi}{16} \times d^3 (80 \times 10^6)$$

$$215.407 \geq \left(\frac{\pi}{16} \right) (d^3) (80 \times 10^6)$$

$$d \geq \sqrt[3]{\frac{16 \times 215.407}{\pi \times 80 \times 10^6}}$$

$$d \geq 0.023935 \text{ m}$$

$$d \geq 23.935 \text{ mm}$$

So, minimum required shaft diameter will be 23.94 mm.

End of Solution

Q.54 A straight-teeth horizontal slab milling cutter is shown in the figure. It has 4 teeth and diameter (D) of 200 mm. The rotational speed of the cutter is 100 rpm and the linear feed given to the workpiece is 1000 mm/minute. The width of the workpiece (w) is 100 mm, and the entire width is milled in a single pass of the cutter. The cutting force/tooth is given by $F = K t_c w$, where specific cutting force $K = 10 \text{ N/mm}^2$, w is the width of cut, and t_c is the uncut chip thickness.

The depth of cut (d) is $D/2$, and hence the assumption of $\frac{d}{D} \ll 1$ is invalid. The maximum cutting force required is _____ kN (round off to one decimal place).

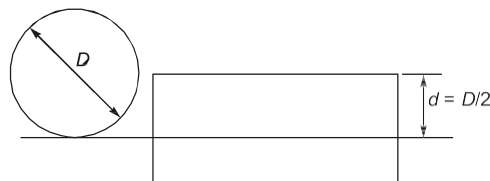

Ans. (2.5) (2.4 to 2.6)

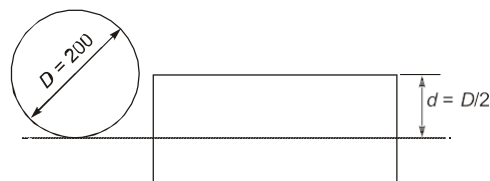

Given:

- Number of teeth, $n = 4$
- Diameter of cutter, $D = 200$ mm
- Rotational speed, $N = 100$ rpm
- Linear feed to workpiece = 1000 mm/min
- Width of workpiece, $w = 100$ mm
- Cutting force/tooth, $F = kt_c w$
- Specific cutting force, $k = 10$ N/mm²

$$\text{Depth of cut, } d = \frac{D}{2}$$

$$\text{Feed } (f) = \frac{1000}{100} = 10 \text{ mm/rev}$$

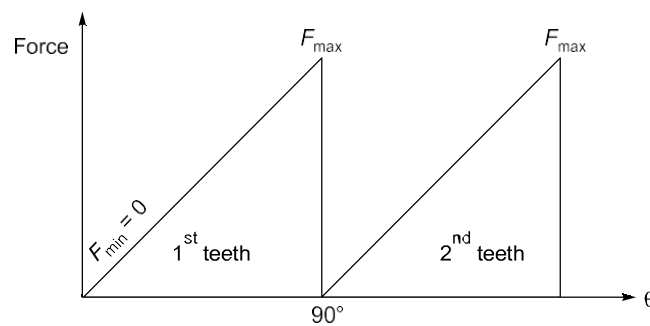

Torque diagram

So, uncut chip thickness,

$$t_{c,max} = \frac{2f}{n} \sqrt{\frac{d}{D} \left(1 - \frac{d}{D}\right)} = \frac{2 \times 10}{4} \sqrt{\frac{D/2}{D} \left(1 - \frac{D/2}{D}\right)} = 2.5 \text{ mm}$$

$$\begin{aligned} \text{So, Maximum force, } F_{max} &= kt_{c,max} w \\ &= 10 \times 2.5 \times 100 \\ &= 2500 \text{ N} = 2.5 \text{ kN} \end{aligned}$$

End of Solution

Q.55 In an orthogonal machining operation, the cutting and thrust forces are equal in magnitude. The uncut chip thickness is 0.5 mm and the shear angle is 15°. The orthogonal rake angle of the tool is 0° and the width of cut is 2 mm. The workpiece material is perfectly plastic and its yield shear strength is 500 MPa. The cutting force is _____ N (round off to the nearest integer).

Ans. (2732.05) (2700 to 2750)

Given: $\alpha_o = \text{Rake angle} = 0^\circ$

$$F_C = F_T$$

$$\Rightarrow F = N; \text{ then, } \mu = \frac{F}{N}$$

$$\Rightarrow \mu = 1$$

We know that

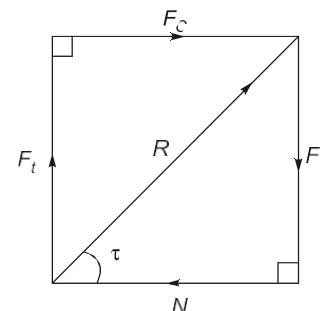

$$\tan \tau = \frac{F}{N} = \mu = 1$$

$$\tau = \tan^{-1}(1) = 45^\circ = \text{Friction angle}$$

$$\text{Shear angle } \theta = 15^\circ$$

$$F_C = \tau_s \frac{bt_t}{\sin \theta} \times \frac{\cos(\tau - \alpha)}{\cos(\theta + \tau - \alpha_o)}$$

$$F_C = 500 \times \frac{2 \times 0.5}{\sin 15^\circ} \times \frac{\cos(45 - 0)}{\cos(15 + 45 - 0)}$$

$$F_C = 2732.05 \text{ N} \approx 2732 \text{ N}$$

End of Solution

- Q.56** The best size wire is fitted in a groove of a metric screw such that the wire touches the flanks of the thread on the pitch line as shown in the figure. The pitch (p) and included angle of the thread are 4 mm and 60° , respectively. The diameter of the best size wire is _____ mm (round off to 2 decimal places).

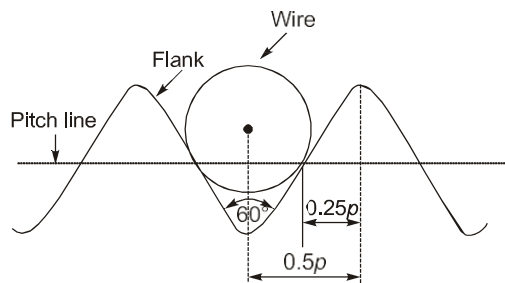

Ans. (2.309) (2.29 to 2.33)

Given: $p = 4 \text{ mm}$, Thread angle, $\alpha = 60^\circ$

$$\begin{aligned} \text{So, Best wire size} &= \frac{p}{2} \sec \frac{\alpha}{2} = \frac{4}{2} \sec \frac{60}{2} \\ &= 2 \sec 30 \\ &= 2 \times 1.154 \text{ mm} = 2.309 \text{ mm} \end{aligned}$$

End of Solution

- Q.57** In a direct current arc welding process, the power source has an open circuit voltage of 100 V and short circuit current of 1000 A. Assume a linear relationship between voltage and current. The arc voltage (V) varies with the arc length (l) as $V = 10 + 5l$, where V is in volts and l is in mm. The maximum available arc power during the process is _____ kVA (in integer).

Ans. (25) (25 to 25)

Given: $V_o = 100 \text{ V}$, $I_s = 1000 \text{ A}$

$$\text{Max. power: } V_a = 10 + 5l_a \quad \dots \text{ (i)}$$

$$V_t = V_o - \left(\frac{I_t}{I_s}\right)V_o = 100 - \left(\frac{I_t}{1000}\right) \times 100 \quad \dots \text{ (ii)}$$

For stable arc:

$$V_t = V_a$$

$$\Rightarrow 10 + 5I_a = 100 - \frac{I_t}{10}$$

$$I_t = (900 - 50I_a)$$

$$\text{Power} = V_t \times I_t$$

$$P = (10 + 5I_a)(900 - 50I_a)$$

$$\frac{\partial P}{\partial I_a} = 0$$

$$\Rightarrow (I_a) = 8 \text{ mm}$$

$$P_{\max} = 25 \text{ kVA} = 25 \text{ kW}$$

$$P = 25 \text{ kW}$$

Alternative solution:

For linear power source

$$V_t = \frac{V_o}{2} = \frac{100}{2} = 50 \text{ V}$$

$$I_t = \frac{I_s}{2} = \frac{1000}{2} = 500 \text{ A}$$

$$P = V_t \times I_t = 50 \times 500 = 25 \text{ kW}$$

End of Solution

- Q.58** A cylindrical billet of 100 mm diameter and 100 mm length is extruded by a direct extrusion process to produce a bar of L-section. The cross sectional dimensions of this L-section bar are shown in the figure. The total extrusion pressure (p) in MPa for the above process is related to extrusion ratio (r) as

$$p = K_s \sigma_m \left[0.8 + 1.5 \ln(r) + \frac{2l}{d_o} \right]$$

where σ_m is the mean flow strength of the billet material in MPa, l is the portion of the billet length remaining to be extruded in mm, d_o is the initial diameter of the billet in mm, and K_s is the die shape factor.

If the mean flow strength of the billet material is 50 MPa and the die shape factor is 1.05, then the maximum force required at the start of extrusion is _____ kN (round off to one decimal place).

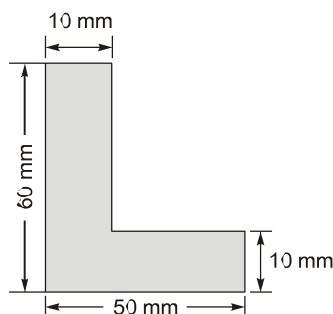

Ans. (2429.3) (2426.0 to 2432.0)

Diameter of cylindrical billet $d_i = 100$ mm

Length of cylindrical billet $l_i = 100$ mm

So, Area $A_i = \frac{\pi}{4} \times 100^2 = 7853.98 \text{ mm}^2$

After extrusion area of final L section

$$A_f = 50 \times 10 + 50 \times 10 \\ = 1000 \text{ mm}^2$$

$$\text{Extrusion ratio, } r = \frac{A_i}{A_f} = \frac{7853.98}{1000} = 7.85398$$

As given in question

$$\text{Total extrusion pressure, } P = k_s \sigma_m \left[0.8 + 1.5 \ln(r) + \frac{2l}{d_o} \right]$$

At start of extrusion,

$$r = 7.85398$$

$$l = 100 \text{ mm}$$

$$\sigma_m = 50 \text{ MPa}$$

$$d_o = 100 \text{ mm}$$

$$k_s = 1.05$$

$$\text{Pressure, } P = 1.05 \times 50 \left[0.8 + 1.5 \ln(7.85398) + 2 \times \frac{100}{100} \right] \\ = 309.296 \text{ MPa}$$

Force required at the start of extrusion,

$$F = P \times A_{\text{initial}} \\ = 309.305 \times \left(\frac{\pi}{4} \times 100^2 \right) \\ = 2429278.724 \text{ N} \\ = 2429.278 \text{ kN}$$

End of Solution

Q.59 A project consists of five activities (A, B, C, D and E). The duration of each activity follows beta distribution. The three time estimates (in weeks) of each activity and immediate predecessor(s) are listed in the table. The expected time of the project completion is _____ weeks (in integer).

Activity	Time estimates (in weeks)			Immediate predecessor(s)
	Optimistic time	Most likely time	Pessimistic time	
A	4	5	6	None
B	1	3	5	A
C	1	2	3	A
D	2	4	6	C
E	3	4	5	B, D

Ans. (15) (15 to 15)

$$t_e = \frac{t_o + t_p + 4t_m}{6}$$

Activity	Time estimates (in weeks)			Estimated time $t_e = \frac{t_o + 4t_m + t_p}{6}$
	Optimistic time (t_o)	Most likely time (t_m)	Pessimistic time (t_p)	
A	4	5	6	5
B	1	3	5	3
C	1	2	3	2
D	2	4	6	4
E	3	4	5	4

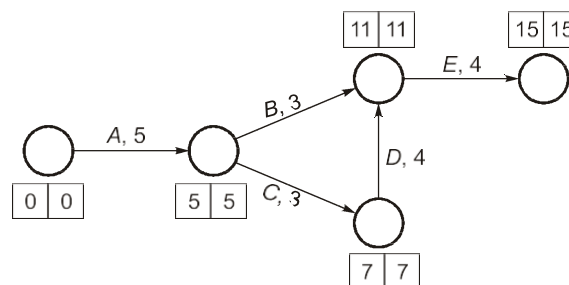

Expected time of the project completion is 15 weeks.

End of Solution

Q.60 A rigid tank of volume of 8 m^3 is being filled up with air from a pipeline connected through a valve. Initially the valve is closed and the tank is assumed to be completely evacuated. The air pressure and temperature inside the pipeline are maintained at 600 kPa and 306 K , respectively. The filling of the tank begins by opening the valve and the process ends when the tank pressure is equal to the pipeline pressure. During the filling process, heat loss to the surrounding is 1000 kJ . The specific heats of air at constant pressure and at constant volume are 1.005 kJ/kg.K and 0.718 kJ/kg.K , respectively. Neglect changes in kinetic energy and potential energy. The final temperature of the tank after the completion of the filling process is _____ K (round off to the nearest integer).

Ans. (395.388) (385 to 405)

Here, $i = \text{Inlet}$, $e = \text{Exit}$,
Initial condition of CV $\Rightarrow 1$
Final condition of CV $\Rightarrow 2$

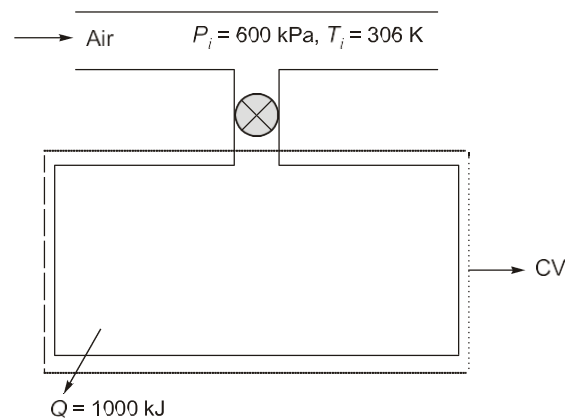

From conservation of mass:

$$m_2 - m_1^0 = m_i - m_e^0$$

$$m_2 = m_e$$

Conservation of energy:

$$U_2 - U_1^0 = m h_i + Q - m_e h_e^0 - W_{CV}^0$$

$$m_2 u_2 = m_2 \times C_p T_i + (-1000) \quad [\because u_2 = C_v T_2 \text{ and } m_i = m_2]$$

$$m_2 C_v T_2 = m_2 C_v T_i - 1000$$

$$\frac{P_2 V}{RT_2} \times C_v \times T_2 = \frac{P_2 V}{RT_2} \times C_v \times T_i - 1000 \quad [\text{By Ideal gas equation}]$$

$$\frac{600 \times 8}{0.287} \times 0.718 = \frac{600 \times 8}{0.287 \times T_2} \times 1.005 \times 306 - 1000$$

$$\Rightarrow T_2 = 395.388 \text{ K}$$

End of Solution

Q.61 At steady state, 500 kg/s of steam enters a turbine with specific enthalpy equal to 3500 kJ/kg and specific entropy equal to 6.5 kJ·kg⁻¹·K⁻¹. It expands reversibly in the turbine to the condenser pressure. Heat loss occurs reversibly in the turbine at a temperature of 500 K. If the exit specific enthalpy and specific entropy are 2500 kJ/kg and 6.3 kJ·kg⁻¹·K⁻¹, respectively, the work output from the turbine is _____ MW (in integer).

Ans. (450) (450 to 450)

For reversible process

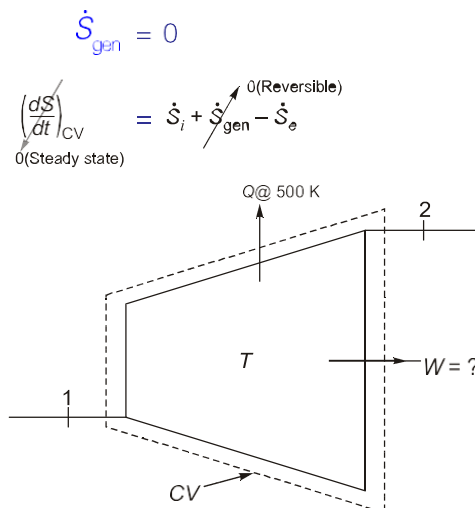

$$0 = \dot{m}s_1 - \left[\dot{m}s_2 + \frac{\dot{Q}}{500} \right]$$

$$0 = 500 \times [6.5 - 6.3] - \frac{\dot{Q}}{500}$$

$$\dot{Q} = 50000 \text{ kW}$$

$$\dot{Q} = 50 \text{ MW}$$

Conservation of energy:

$$\dot{E}_{in} = \dot{E}_{exit}$$

$$\dot{m}h_1 = \dot{m}h_2 + \dot{Q} + \dot{W}$$

$$\dot{m}(h_1 - h_2) = \dot{Q} + \dot{W}$$

$$500 (3500 - 2500) = 50000 + \dot{W}$$

$$\dot{W} = 450000 \text{ kW}$$

$$\dot{W} = 450 \text{ MW}$$

End of Solution

Q.62 A uniform wooden rod (specific gravity = 0.6, diameter = 4 cm and length = 8 m) is immersed in the water and is hinged without friction at point A on the waterline as shown in the figure. A solid spherical ball made of lead (specific gravity = 11.4) is attached to the free end of the rod to keep the assembly in static equilibrium inside the water. For simplicity, assume that the radius of the ball is much smaller than the length of the rod.

Assume density of water = 10^3 kg/m^3 and $\pi = 3.14$.

Radius of the ball is _____ cm (round off to 2 decimal places).

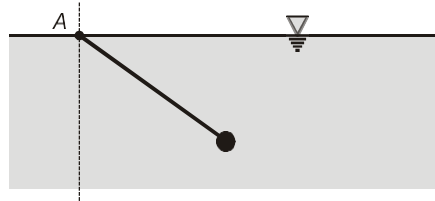

Ans. (3.58) (3.48 to 3.70)

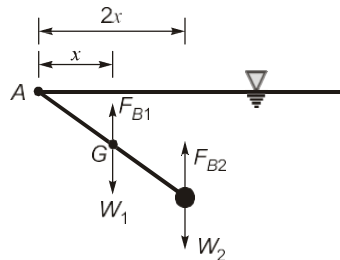

$$W_1 = \rho_1 g \pi r_1^2 l$$

$$W_2 = \rho_2 g \frac{4}{3} \pi r_2^3$$

Where,

r_1 = Radius of rod

r_2 = Radius of sphere

$$\text{Buoyant force} = \rho_F g V_{fd} = \rho_F g \left[\pi r_1^2 l + \frac{4}{3} \pi r_2^3 \right]$$

$$\Sigma M_A = 0 \text{ for equilibrium}$$

$$W_1 x + W_2 (2x) = F_{B1} \times x + F_{B2} \times 2x$$

$$\rho_1 g \pi r_1^2 l + 2 \rho_2 g \frac{4}{3} \pi r_2^3 = \rho_w g \left[\pi r_1^2 l + \frac{4}{3} \pi r_2^3 \times 2 \right]$$

$$\pi S_1 r_1^2 + 2 S_2 g \frac{4}{3} \pi r_2^3 = \pi r_1^2 l + \frac{4}{3} \pi r_2^3 \times 2 \quad \left[\text{Here, } S_1 = \frac{\rho_1}{\rho_w} \text{ and } S_2 = \frac{\rho_2}{\rho_w} \right]$$

$$(2 S_2 - 2) \frac{4}{3} r_2^3 = (-S_1 + 1) r_1^2 l$$

$$(2 \times 11.4 - 2) \frac{4}{3} r_2^3 = (1 - 0.6) \times 8 \times (0.02)^2$$

$$r_2 = 0.0358 \text{ m}$$

$$r_2 = 3.58 \text{ cm}$$

End of Solution

Q.63 Consider steady state, one-dimensional heat conduction in an infinite slab of thickness $2L$ ($L = 1$ m) as shown in the figure. The conductivity (k) of the material varies with temperature as $k = CT$, where T is the temperature in K, and C is a constant equal to $2 \text{ W}\cdot\text{m}^{-1}\cdot\text{K}^{-2}$. There is a uniform heat generation of $1280 \text{ kW}/\text{m}^3$ in the slab. If both faces of the slab are maintained at 600 K , then the temperature at $x = 0$ is _____ K (in integer).

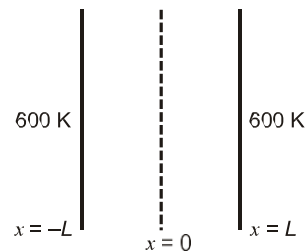

Ans. (1000) (1000 to 1000)

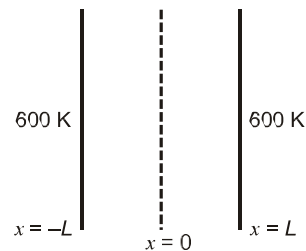

Given: $k = CT$, where $C = 2$

Steady state, one-dimensional heat conduction

$$\frac{\partial}{\partial x} \left(k \frac{\partial T}{\partial x} \right) = -\dot{q}$$

On integrating,

$$k \frac{dT}{dx} = -\dot{q}x + C_1$$

$$2T \frac{dT}{dx} = -\dot{q}x + C_1$$

$$TdT = \left[\frac{-\dot{q}x + C_1}{2} \right] dx$$

On integrating,
$$\frac{T^2}{2} = \frac{1}{2} \left[-\frac{\dot{q}x^2}{2} + C_1x \right] + C_2 \quad \dots (i)$$

Boundary conditions:

At $x = +L = +1\text{m} \Rightarrow T = 600 \text{ K}$

$$600^2 = \frac{-1280 \times 10^3 \times 1^2}{2} + C_1 \times 1 + C_2$$

$\Rightarrow C_1 + C_2 = 10^6 \quad \dots (ii)$

At $x = -L = -1 \Rightarrow T = 600 \text{ K}$

$$600^2 = \frac{-1280 \times 10^3 \times (-1)^2}{2} + C_1 \times (-1) + C_2$$

$\Rightarrow -C_1 + C_2 = 10^6 \quad \dots (iii)$

By equation (ii) and (iii) we get,

and $C_1 = 0$
 $C_2 = 10^6$
 So by equation (i) we get

$$T^2 = -\frac{\dot{q}x^2}{2} + C_2$$

So, at $x = 0$

$$[T(0)]^2 = C_2$$

$$[T(0)] = \sqrt{C_2} = \sqrt{10^6}$$

⇒

$$T = 10^3 = 1000 \text{ K}$$

$$T_{x=0} = 1000 \text{ K}$$

End of Solution

Q.64 Saturated vapor at 200 °C condenses to saturated liquid at the rate of 150 kg/s on the shell side of a heat exchanger (enthalpy of condensation $h_{fg} = 2400 \text{ kJ/kg}$). A fluid with $c_p = 4 \text{ kJ}\cdot\text{kg}^{-1}\cdot\text{K}^{-1}$. enters at 100°C on the tube side. If the effectiveness of the heat exchanger is 0.9, then the mass flow rate of the fluid in the tube side is ____ kg/s (in integer).

Ans. (1000) (1000 to 1000)

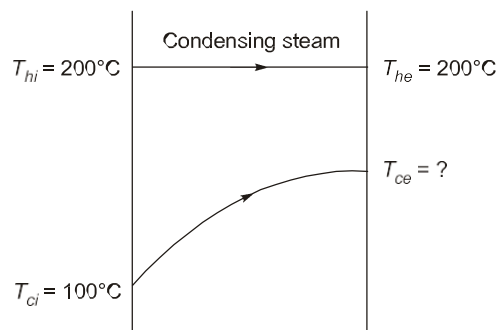

For exit temperature of cold fluid:

$$(\dot{m}C_p)_{\text{hot fluid}} \rightarrow \infty$$

∴

$$C = 0$$

$$\epsilon = \frac{T_{ce} - T_{ci}}{T_{hi} - T_{ci}} = 0.9$$

$$\frac{T_{ce} - 100}{200 - 100} = 0.9$$

⇒

$$T_{ce} = 190^\circ\text{C}$$

By heat balance equation:

$$\dot{m}_{\text{condensing}} \times h_{fg} = \dot{m}_c C_{pc} \times (T_{ce} - T_{ci})$$

$$150 \times 2400 = \dot{m}_c \times 4.0 \times (190 - 100)$$

Mass flow rate of cold fluid, $\dot{m}_c = 1000 \text{ kg/s}$

End of Solution

Q.65 Consider a hydrodynamically and thermally fully-developed, steady fluid flow of 1 kg/s in a uniformly heated pipe with diameter of 0.1 m and length of 40 m. A constant heat flux of magnitude 15000 W/m² is imposed on the outer surface of the pipe. The bulk-mean temperature of the fluid at the entrance to the pipe is 200°C. The Reynolds number (Re) of the flow is 85000, and the Prandtl number (Pr) of the fluid is 5. The thermal conductivity and the specific heat of the fluid are 0.08 W·m⁻¹·K⁻¹ and 2600 J·kg⁻¹·K⁻¹, respectively. The correlation $Nu = 0.023 Re^{0.8} Pr^{0.4}$ is applicable, where the Nusselt Number (Nu) is defined on the basis of the pipe diameter. The pipe surface temperature at the exit is _____ °C (round off to the nearest integer).

Ans. (321) (317 to 324)

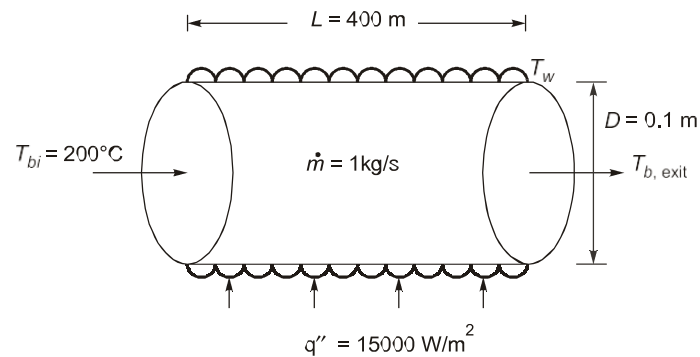

Given: $Re = 85000$, $Pr = 5$

To get $T_{b, \text{exit}}$:

$$q'' \times \pi DL = \dot{m}_f \times C_p (T_{b, \text{exit}} - T_{b, \text{inlet}})$$

$$15000 \times \pi \times 0.1 \times 40 = 1 \times 2600 \times (T_{b, \text{exit}} - 200)$$

$$\Rightarrow T_{b, \text{exit}} = 272.498^\circ\text{C}$$

$$\text{Nusselt number, } Nu = \frac{hD}{k} = 0.023 Re^{0.8} Pr^{0.4}$$

$$\text{So, } \frac{h \times 0.1}{0.08} = 0.023 \times (85000)^{0.8} \times 5^{0.4}$$

$$h = 307.56 \text{ W/m}^2\text{K}$$

Now for T_w (Wall temperature):

By Newton's law of cooling,

$$q'' = h(T_{w, \text{exit}} - T_{b, \text{exit}})$$

$$15000 = (T_{w, \text{exit}} - 272.498)$$

$$T_{w, \text{exit}} = \frac{15000}{307.56} + 272.498$$

$$= 48.7 + 6769 + 272.498$$

$$T_{w, \text{exit}} = 321.26^\circ\text{C} \approx 321^\circ\text{C}$$

End of Solution

